



# ALLIED MACHINE & ENGINEERING

为当今制造业提供制孔解决方案



钻削



镗孔



铰孔



螺纹加工



## 滚筒抛光

► 抛光

采用S.C.A.M.I.® 滚筒抛光工艺的精加工  
解决方案



特殊应用



S.C.A.M.I.®

# 滚筒抛光系统

通孔样式 | 盲孔样式



## S.C.A.M.I.®

### 获得您所需的精加工质量

美国联合机械工程公司以提供S.C.A.M.I.®滚轮抛光工具而骄傲。这些孔精加工刀具在通孔和盲孔应用中均可提供极高品质的表面质量。通过滚轮抛光，您不再需要速度慢、成本高的精加工过程以及研磨、珩磨和精研等二次加工。

滚轮抛光工具不仅能打造出光滑的表面质量，还能硬化材料，提高零件的耐磨性。这种一次加工的优势就在于能够实现您对美国联合机械工程公司期待的孔质量。

打造精细的表面质量	提高耐磨性和防腐性	消除其他过程，节省资金
-----------	-----------	-------------

### 适用行业



航空航天



农业



汽车



枪械



一般加工



油气



可再生能源

您及他人的人身安全至关重要。本目录包含重要安全信息。请务必阅读并遵守所有安全注意事项。



该三角形是一种安全隐患符号，用于提醒您注意可能导致刀具故障和严重人身伤害的潜在安全隐患。

当您在目录中看到该符号时，请查找该三角形附近或附近文字中提到的相关安全信息。

本目录中也使用了安全信号词，安全信息在这些信号词后面。

#### 警告

警告 (如上所示) 表示不遵守该信息中的注意事项可能导致刀具故障和严重的人身伤害。

注意表示不遵守该信息中的注意事项可能导致刀具或机床损坏，但不会导致人身伤害。

此外，还使用了注释和重要说明。这些是您必须阅读并遵守的重要信息，但与安全无关。

有关最新信息和规程，请访问 [www.alliedmachine.com](http://www.alliedmachine.com)。

## 参考图标

以下图标将始终贯穿本目录，以帮助您在不同的产品之间导航。



技术信息  
相应零件的详细说明和信息

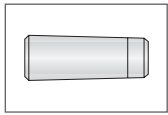

通孔辊  
指的是可用于通孔抛光工具的辊

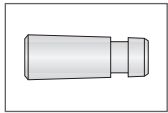

盲孔辊  
指的是可用于盲孔抛光工具的辊

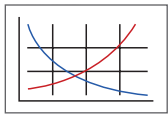

推荐的切削参数  
可实现最佳安全抛光的速度和进给推荐值

系列	直径范围	
	英制 (in)	公制 (mm)
H	0.1555 - 0.5028	3.95 - 12.77
I	0.4976 - 0.6634	12.64 - 16.85
K	0.6535 - 0.9740	16.60 - 24.74
L	0.9661 - 1.2268	24.54 - 31.16
F	0.9661 - 1.2268	24.54 - 31.16
M	1.2146 - 1.4118	30.85 - 35.86
N	1.4020 - 1.8492	35.61 - 46.97
O	1.8390 - 2.2240	46.71 - 56.49
P	2.2138 - 2.7240	56.23 - 69.19
Q	2.7138 - 3.3492	68.93 - 85.07
R	3.3390 - 4.0992	84.81 - 104.12
S	4.0890 - 5.0370	103.86 - 127.94
T	5.0354 - 5.9016	127.90 - 149.90
U	5.9016 - 6.5315	149.90 - 165.90



美国联合机械工程公司通过与S.C.A.M.I. s.n.c.签订的独家供货协议提供滚筒抛光工具。

S.C.A.M.I.这家意大利制造商在生产优质切削刀具方面已有40多年的历史。

如需有关所有美国联合机械工程公司产品的附加信息，请访问[www.alliedmachine.com](http://www.alliedmachine.com)；如需技术援助，请联系我们的应用工程部门。

## 引言

滚筒抛光概述	2 - 3
产品供应	4
产品选择指南	5
产品命名法	6

## 抛光系列

H系列	7 - 11
I系列	12 - 13
K系列	14 - 15
L系列	16 - 17
F系列	18 - 19
M系列	20 - 21
N系列	22 - 23
O系列	24 - 25
P系列	26 - 27
Q系列	28 - 29
R系列	30 - 31
S系列	32 - 33
T系列	34 - 35
U系列	36 - 37

辊	38 - 39
---	---------

## 技术信息

直径调整	40
抛光工具工作原理	41

## 推荐的切削参数

英制 (in)	42 - 43
公制 (mm)	44 - 45

## 滚筒抛光概述

### 滚筒抛光原理

滚筒抛光是可以产生精细表面光洁度的冷作工艺。淬火辊进行行星旋转会对金属表面造成压力。与造成很大截面变化的冷轧不同，滚筒抛光在工件表面进行冷加工，以改进表面结构。

所有加工表面均由一系列“峰尖”和“谷底”组成，它们都有不规则的高度和间距。滚筒抛光造成的塑性变形是“峰尖”处发生的材料位移。在压力下，“峰尖”处的材料流向“谷”。在这一过程中，工具痕迹和不规则处被轧平，产生有韧性、经过加工硬化的表面，不仅光洁如镜，并且防腐耐磨。

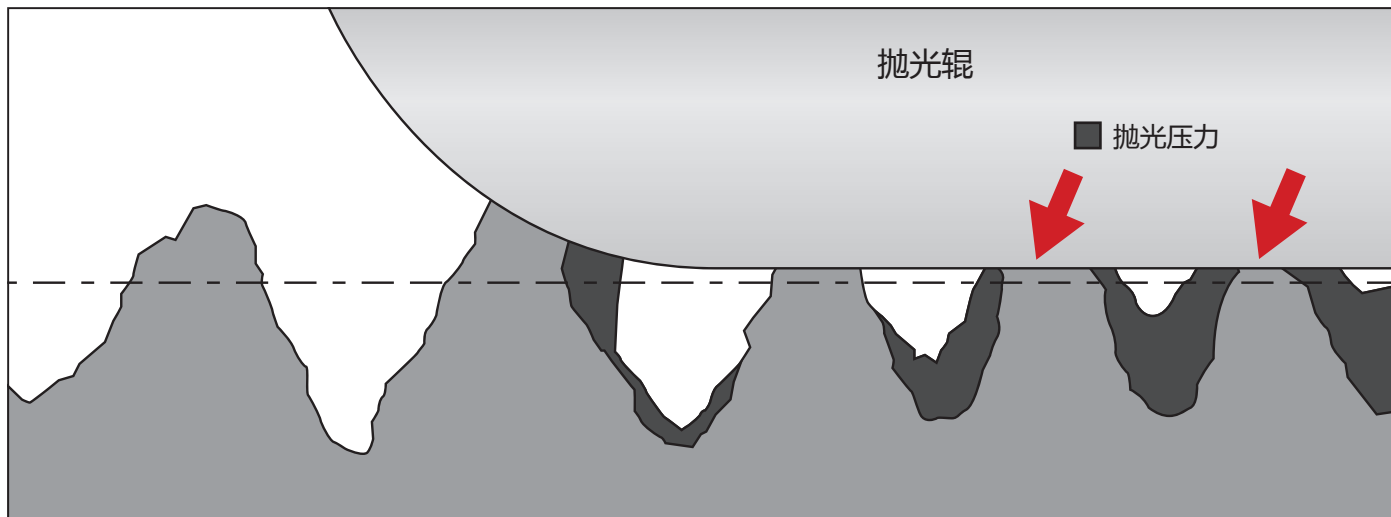

### 滚筒抛光的优势：冶金属性

- 颗粒结构经过压缩和精炼。
- 紧凑的表面比研磨或珩磨表面更光滑、更坚硬、更耐磨。
- 这一过程能减少表面的多孔性，还能清除可能容纳反应性物质或污染物的划痕。这样可以提高防腐性。
- 根据材料，表面硬度可提高10个点(洛氏C)。这样可以消除对热处理的需要。
- 塑性变形会在零件表面引起残余压应力。这会提高零件的力学属性并延长疲劳寿命，因为零件上的任何力必须在疲劳状况发生之前克服这些残余应力以及材料的抗拉强度。

### 滚筒抛光的优势：表面光洁度

- 为任何可加工金属打造高光亮度。
- 一次走刀即可将被镗削、绞削或车削至125微英寸或以上的表面精加工至4微英寸CLA或更小(在125至300 mm/min的进给速率下)。
- 滚筒抛光可以取代研磨、珩磨、精研以及其他昂贵的二次加工。
- 轧平刀具痕迹。

### 过程

- 与加工表面的首次接触发生在A区域。
- 由于超出表面屈服点，塑性变形发生在B区域。
- D区域是加压深度。
- 材料承受最大压缩应变后(C区域)，开始通过精加工区域有弹性地消除应力(E区域)。
- 这样可以产生光滑的表面和峰值明显的压缩残余应力。
- 压缩过程中在材料上形成的应力向中心逐渐减小。这些应力达到表面以下约1 mm。这会增强表面硬度。

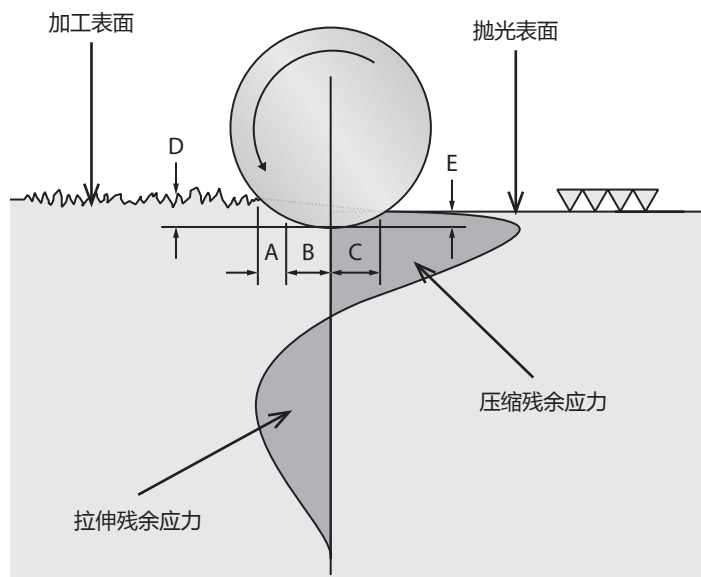

## 滚筒抛光概述

### 何时应进行滚筒抛光

#### 滚筒抛光的条件

滚筒抛光是一种用于实现精细孔光洁度的冷作工艺。为了实现最佳结果，请遵守以下基准：

- 精加工：工件材料的延展性和硬度以及表面制备显示经过抛光的光洁度质量。
- 可加工性：任何达到RC40的可锻造延展性材料均可进行滚筒抛光。
- 加工表面的属性：对于间断面在圆周10%以内的工件，可使用标准工具成功进行抛光 (参见图1和2)。

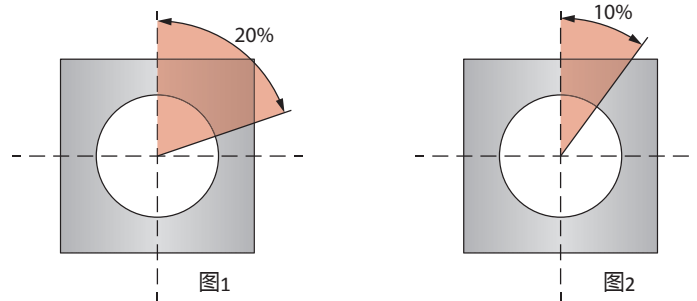

- 抛光件公差：抛光达到的公差范围与预加工达到的公差范围相等，因为不会去除任何材料。

理想的抛光表面包含一连串的高峰。这些高峰是由制备工具的规律进给造成的 (参见图3)。建议使用ALVAN®可涨头铰刀进行预抛光，因为该铰刀可制造出均匀的粗糙度，且公差范围在H6 - H7之间。



图3

如有因切削刀具故障导致的预加工锥度和表面不平整，必须加以注明，因为滚筒抛光工艺无法校正这些情况 (参见图4和5)。



图4

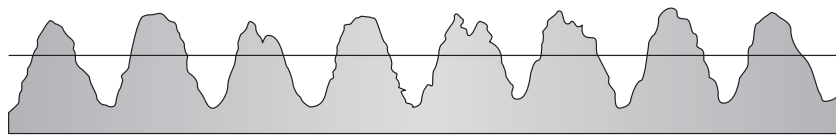

图5

产品供应

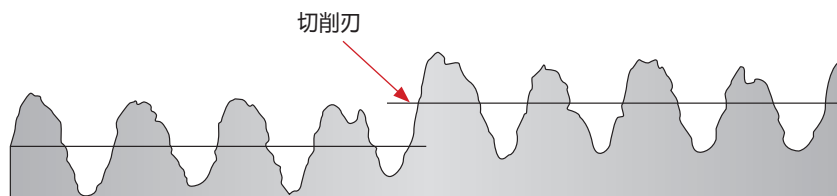

通孔样式

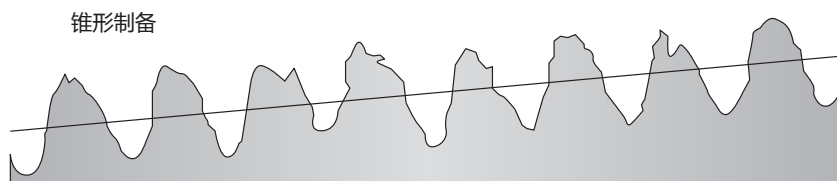
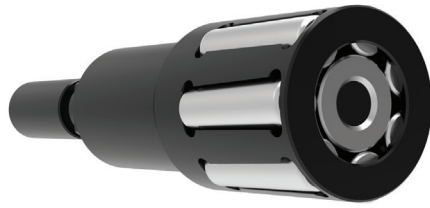
0.1555" - 6.5315" (3.95 mm - 165.90 mm)

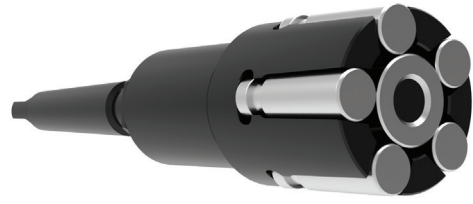

盲孔样式

0.2319" - 6.5315" (5.89 mm - 165.90 mm)

滚筒抛光工具的优势

- ✓ 实现精确的尺寸控制  
公差在0.0005"以内或更小 (取决于变量, 例如材料)
- ✓ 生成精细的表面光洁度  
1 - 16微英寸 (Ra) 之间 (0.03 - 0.4 Ra micromillimeters)
- ✓ 增强表面硬度  
增强5 - 10%或更多
- ✓ 执行更整洁的加工  
比珩磨或其他抛光方法更干净
- ✓ 功能丰富  
因为可以在任何旋转主轴上进行加工
- ✓ 不再需要速度慢、成本高的精加工过程和二次加工  
例如研磨、珩磨、精研等

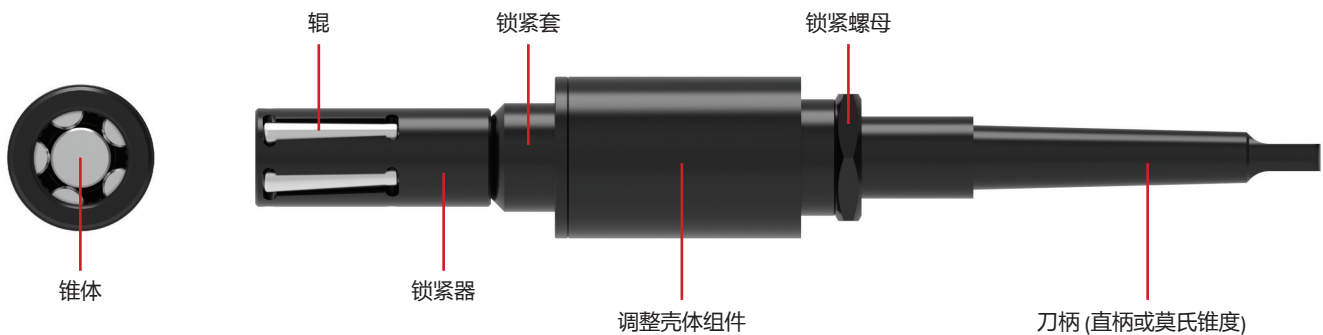















刀具部件

所有滚筒抛光工具 (通孔和盲孔) 均有基本的抛光工具组件组成, 包括:

- 锁紧器
- 锥体
- 辊
- 刀柄 (直柄或莫氏锥度)

# 产品选择指南

Series	Diameter Range (inch / mm)						Length				
	0 - 1	1 - 2	2 - 3	3 - 4	4 - 5	5 - 6	6 - 7	Short	Standard	Long	Unlimited
	0 - 25.4	25.4 - 50.8	50.8 - 76.2	76.2 - 101.6	101.6 - 127	127 - 152.4	152.4 - 177.8				
H* Mini								<input checked="" type="checkbox"/>	<input checked="" type="checkbox"/>		
H*								<input checked="" type="checkbox"/>	<input checked="" type="checkbox"/>	<input checked="" type="checkbox"/>	
I								<input checked="" type="checkbox"/>	<input checked="" type="checkbox"/>	<input checked="" type="checkbox"/>	
K								<input checked="" type="checkbox"/>	<input checked="" type="checkbox"/>	<input checked="" type="checkbox"/>	
L								<input checked="" type="checkbox"/>	<input checked="" type="checkbox"/>	<input checked="" type="checkbox"/>	
F											<input checked="" type="checkbox"/>
M											<input checked="" type="checkbox"/>
N											<input checked="" type="checkbox"/>
O											<input checked="" type="checkbox"/>
P											<input checked="" type="checkbox"/>
Q											<input checked="" type="checkbox"/>
R											<input checked="" type="checkbox"/>
S											<input checked="" type="checkbox"/>
T											<input checked="" type="checkbox"/>
U											<input checked="" type="checkbox"/>

\*For H series: through hole tools start at 0.1555" (3.95mm) and blind hole tools start at 0.2319" (5.89mm)

## 何时 订购

有时，两个相邻的系列可能会有直径重叠。如果您所需的直径在该重叠范围内，应选择两个中较高的系列。

示例：

您需要直径为24.64 mm的刀具。K系列和L系列都有该直径刀具。

- K系列直径范围 = 16.60 mm - 24.74 mm
- L系列直径范围 = 24.54 mm - 31.16 mm

在这种情况下，您可选择包含24.64直径的L系列。

## 产品命名法

### 滚筒抛光工具

RDK	H	-	2	1	0	-	004,70
1	2		3	4	5		6

<b>1. 抛光工具类型</b> RDK = 通孔 RSK = 盲孔	<b>2. 系列</b> H = H系列      F = F系列      P = P系列      T = T系列 I = I系列      M = M系列      Q = Q系列      U = U系列 K = K系列      N = N系列      R = R系列 L = L系列      O = O系列      S = S系列	<b>3. 刀柄类型</b> 1 = 直槽 2 = 莫氏锥度
<b>4. 长度</b> 0 = 无限制 1 = 短 2 = 标准 3 = 长	<b>5. 锁紧器样式</b> 0 = 标准	<b>6. 直径</b> 通孔刀具 = 抛光工具范围的最小直径 盲孔刀具 = 要抛光的直径

#### 锥体缩减因数 (盲孔)

抛光盲孔时，锥体不得超出辊端。如果超出，锥体将会碰撞到孔底。每件抛光工具的直径调节范围：

- 对于12.7 mm以下的工具约0.5 mm
- 对于12.7 mm以上的工具约1.0 mm

对于通孔抛光工具，标准锥体值“x”为1。如果使用标准锥体进行盲孔抛光，减小锥体长度是唯一不会使其超出辊端的方法。需要缩减的长度取决于设置直径以及工具所能达到的最小直径。缩减因数(x)可通过以下公式计算，该因数应为2 - 8范围内的整数。

“x”值可能带有小数。如果小数部分低于0.80，为答案舍掉小数部分，如果是0.80或以上，则舍入下一个整数。

<b>直径 (5.89 mm - 12.77 mm)</b> $x = 1 + \frac{Z - Y}{0.05}$ Z = 孔直径 Y = 刀具的最小直径设置 示例：Z = 11.05 Y = 10.71 mm $x = 1 + \frac{11.05 - 10.71}{0.05} = 7.8$ “x”约等于8 正确的锥体：RSTH-038-11025	<b>直径 (12.64 mm - 127.94 mm)</b> $x = 1 + \frac{Z - Y}{0.10}$ Z = 孔直径 Y = 刀具的最小直径设置 示例：Z = 17.76 Y = 17.40 mm $x = 1 + \frac{17.76 - 17.40}{0.10} = 4.6$ “x”约等于4 正确的锥体：RSTK-034-00044	<b>直径 (127.90 mm - 165.90 mm)</b> $xx = 31 + \frac{Z - Y}{0.10}$ Z = 孔直径 Y = 刀具的最小直径设置 示例：Z = 148.20 Y = 147.90 mm $xx = 31 + \frac{148.20 - 147.90}{0.10} = 34$ 正确的锥体：RSTT-034-01480
--	--	---

#### 参考说明

符号	属性
D <sub>1</sub>	直径范围
L <sub>2</sub>	抛光长度
L <sub>3</sub>	参考长度

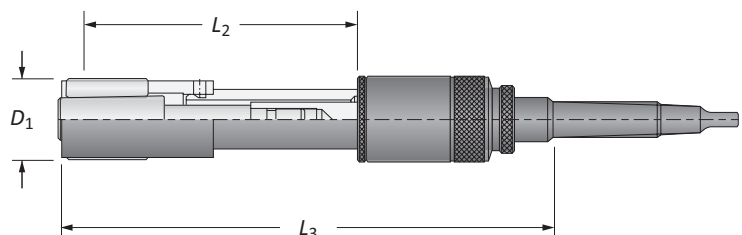





## 滚筒抛光工具 | 通孔

H系列 (迷你) | 直径范围 : 0.1555" - 0.1870" (3.95 mm - 4.75 mm)

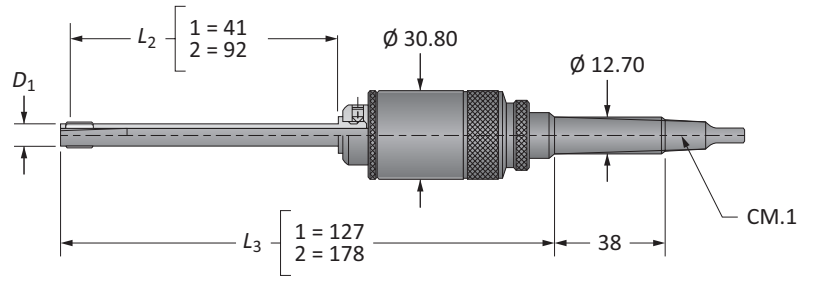

$D_1$		$L$	零件号 包含莫氏锥柄 的总成	备件			
英制 (in)	公制 (mm)			锁紧器	锥体	辊	辊数量
0.1555 - 0.1634	3.95 - 4.15	1	RDKH-012-00395	RDCH-012-10005	RDTH-031-10012	RDRY-704-00047	3
0.1555 - 0.1634	3.95 - 4.15	2	RDKH-022-00395	RDCH-012-20005	RDTH-031-20012	RDRY-704-00047	3
0.1638 - 0.1713	4.16 - 4.35	1	RDKH-012-00416	RDCH-012-10006	RSTH-035-10012	RDRY-704-00047	3
0.1638 - 0.1713	4.16 - 4.35	2	RDKH-022-00416	RDCH-012-20006	RSTH-035-20012	RDRY-704-00047	3
0.1717 - 0.1791	4.36 - 4.55	1	RDKH-012-00436	RDCH-012-10007	RDTH-031-10013	RDRY-704-00047	3
0.1717 - 0.1791	4.36 - 4.55	2	RDKH-022-00436	RDCH-012-20007	RDTH-031-20013	RDRY-704-00047	3
0.1795 - 0.1870	4.56 - 4.75	1	RDKH-012-00456	RDCH-012-10008	RSTH-035-10013	RDRY-704-00047	3
0.1795 - 0.1870	4.56 - 4.75	2	RDKH-022-00456	RDCH-012-20008	RSTH-035-20013	RDRY-704-00047	3

注释：每种滚筒抛光工具都装配有锁紧器、锥体和辊。

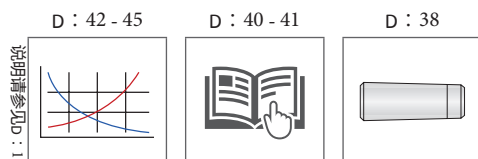

说明请参见 D : 1

滚筒抛光工具 | 通孔

H系列 | 直径范围 : 0.1850" - 0.5028" (4.70 mm - 12.77 mm)

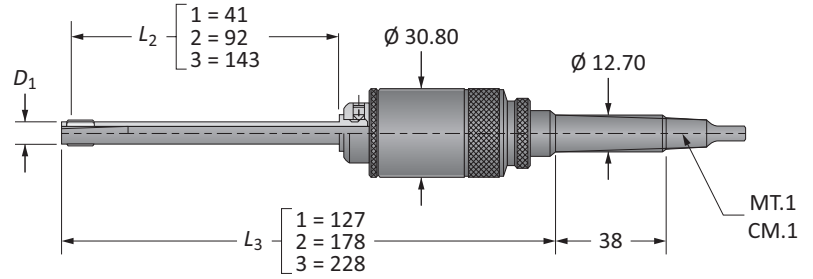

D <sub>1</sub>		L	零件号		备件			
英制 (in)	公制 (mm)		包含莫氏锥柄的总成	包含直柄的总成	锁紧器	锥体	辊	辊数量
0.1850 - 0.1929	4.70 - 4.90	1	RDKH-210-00470	RDKH-110-00470	RDCH-011-10012	RDTH-031-10012	RDRY-704-00062	3
0.1850 - 0.1929	4.70 - 4.90	2	RDKH-220-00470	RDKH-120-00470	RDCH-011-20012	RDTH-031-20012	RDRY-704-00062	3
0.1850 - 0.1929	4.70 - 4.90	3	RDKH-230-00470	RDKH-130-00470	RDCH-011-30012	RDTH-031-30012	RDRY-704-00062	3
0.1917 - 0.2035	4.87 - 5.17	1	RDKH-210-00487	RDKH-110-00487	RDCH-011-10011	RSTH-033-10012	RDRY-704-00062	3
0.1917 - 0.2035	4.87 - 5.17	2	RDKH-220-00487	RDKH-120-00487	RDCH-011-20011	RSTH-033-20012	RDRY-704-00062	3
0.1917 - 0.2035	4.87 - 5.17	3	RDKH-230-00487	RDKH-130-00487	RDCH-011-30011	RSTH-033-30012	RDRY-704-00062	3
0.1996 - 0.2200	5.07 - 5.59	1	RDKH-210-00507	RDKH-110-00507	RDCH-011-10013	RDTH-031-10013	RDRY-704-00062	5
0.1996 - 0.2200	5.07 - 5.59	2	RDKH-220-00507	RDKH-120-00507	RDCH-011-20013	RDTH-031-20013	RDRY-704-00062	5
0.1996 - 0.2200	5.07 - 5.59	3	RDKH-230-00507	RDKH-130-00507	RDCH-011-30013	RDTH-031-30013	RDRY-704-00062	5
0.2161 - 0.2358	5.49 - 5.99	1	RDKH-210-00549	RDKH-110-00549	RDCH-011-10014	RDTH-031-10013	RDRY-704-00070	5
0.2161 - 0.2358	5.49 - 5.99	2	RDKH-220-00549	RDKH-120-00549	RDCH-011-20014	RDTH-031-20013	RDRY-704-00070	5
0.2161 - 0.2358	5.49 - 5.99	3	RDKH-230-00549	RDKH-130-00549	RDCH-011-30014	RDTH-031-30013	RDRY-704-00070	5
0.2319 - 0.2524	5.89 - 6.41	1	RDKH-210-00589	RDKH-110-00589	RDCH-011-10015	RDTH-031-10015	RDRY-704-00070	5
0.2319 - 0.2524	5.89 - 6.41	2	RDKH-220-00589	RDKH-120-00589	RDCH-011-20015	RDTH-031-20015	RDRY-704-00070	5
0.2319 - 0.2524	5.89 - 6.41	3	RDKH-230-00589	RDKH-130-00589	RDCH-011-30015	RDTH-031-30015	RDRY-704-00070	5
0.2484 - 0.2681	6.31 - 6.81	1	RDKH-210-00631	RDKH-110-00631	RDCH-011-10016	RDTH-031-10015	RDRY-704-00078	5
0.2484 - 0.2681	6.31 - 6.81	2	RDKH-220-00631	RDKH-120-00631	RDCH-011-20016	RDTH-031-20015	RDRY-704-00078	5
0.2484 - 0.2681	6.31 - 6.81	3	RDKH-230-00631	RDKH-130-00631	RDCH-011-30016	RDTH-031-30015	RDRY-704-00078	5
0.2642 - 0.2839	6.71 - 7.21	1	RDKH-210-00671	RDKH-110-00671	RDCH-011-10017	RDTH-031-10017	RDRY-704-00078	5
0.2642 - 0.2839	6.71 - 7.21	2	RDKH-220-00671	RDKH-120-00671	RDCH-011-20017	RDTH-031-20017	RDRY-704-00078	5
0.2642 - 0.2839	6.71 - 7.21	3	RDKH-230-00671	RDKH-130-00671	RDCH-011-30017	RDTH-031-30017	RDRY-704-00078	5
0.2803 - 0.3000	7.12 - 7.62	1	RDKH-210-00712	RDKH-110-00712	RDCH-011-10018	RDTH-031-10017	RDRY-704-00086	5
0.2803 - 0.3000	7.12 - 7.62	2	RDKH-220-00712	RDKH-120-00712	RDCH-011-20018	RDTH-031-20017	RDRY-704-00086	5
0.2803 - 0.3000	7.12 - 7.62	3	RDKH-230-00712	RDKH-130-00712	RDCH-011-30018	RDTH-031-30017	RDRY-704-00086	5
0.2945 - 0.3142	7.48 - 7.98	1	RDKH-210-00748	RDKH-110-00748	RDCH-011-10019	RDTH-031-10019	RDRY-704-00086	5
0.2945 - 0.3142	7.48 - 7.98	2	RDKH-220-00748	RDKH-120-00748	RDCH-011-20019	RDTH-031-20019	RDRY-704-00086	5
0.2945 - 0.3142	7.48 - 7.98	3	RDKH-230-00748	RDKH-130-00748	RDCH-011-30019	RDTH-031-30019	RDRY-704-00086	5
0.3102 - 0.3299	7.88 - 8.38	1	RDKH-210-00788	RDKH-110-00788	RDCH-011-10020	RDTH-031-10019	RDRY-704-00093	5
0.3102 - 0.3299	7.88 - 8.38	2	RDKH-220-00788	RDKH-120-00788	RDCH-011-20020	RDTH-031-20019	RDRY-704-00093	5
0.3102 - 0.3299	7.88 - 8.38	3	RDKH-230-00788	RDKH-130-00788	RDCH-011-30020	RDTH-031-30019	RDRY-704-00093	5
0.3260 - 0.3461	8.28 - 8.79	1	RDKH-210-00828	RDKH-110-00828	RDCH-011-10021	RDTH-031-10021	RDRY-704-00093	5
0.3260 - 0.3461	8.28 - 8.79	2	RDKH-220-00828	RDKH-120-00828	RDCH-011-20021	RDTH-031-20021	RDRY-704-00093	5
0.3260 - 0.3461	8.28 - 8.79	3	RDKH-230-00828	RDKH-130-00828	RDCH-011-30021	RDTH-031-30021	RDRY-704-00093	5

注释：每种滚筒抛光工具都装配有锁紧器、锥体和辊。

说明请参见 D : 42 - 45    D : 40 - 41    D : 38



## 滚筒抛光工具 | 通孔 (续)

H系列 | 直径范围 : 0.1850" - 0.5028" (4.70 mm - 12.77 mm)

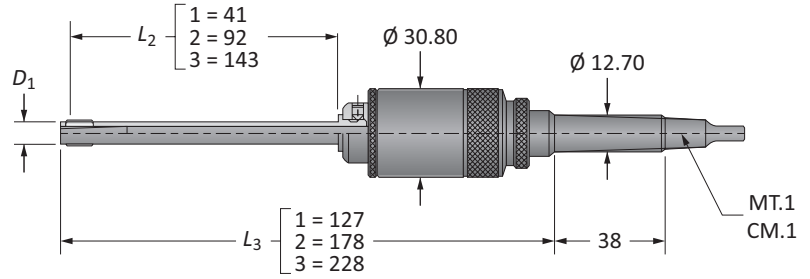

D <sub>1</sub>		L	零件号		备件			
英制 (in)	公制 (mm)		包含莫氏锥柄的总成	包含直柄的总成	锁紧器	锥体	辊	辊数量
0.3410 - 0.3606	8.66 - 9.16	1	<b>RDKH-210-00866</b>	<b>RDKH-110-00866</b>	RDCH-011-10022	RDTH-031-10019	RDRY-704-00109	5
0.3410 - 0.3606	8.66 - 9.16	2	<b>RDKH-220-00866</b>	<b>RDKH-120-00866</b>	RDCH-011-20022	RDTH-031-20019	RDRY-704-00109	5
0.3410 - 0.3606	8.66 - 9.16	3	<b>RDKH-230-00866</b>	<b>RDKH-130-00866</b>	RDCH-011-30022	RDTH-031-30019	RDRY-704-00109	5
0.3567 - 0.3768	9.06 - 9.57	1	<b>RDKH-210-00906</b>	<b>RDKH-110-00906</b>	RDCH-011-10023	RDTH-031-10021	RDRY-704-00109	5
0.3567 - 0.3768	9.06 - 9.57	2	<b>RDKH-220-00906</b>	<b>RDKH-120-00906</b>	RDCH-011-20023	RDTH-031-20021	RDRY-704-00109	5
0.3567 - 0.3768	9.06 - 9.57	3	<b>RDKH-230-00906</b>	<b>RDKH-130-00906</b>	RDCH-011-30023	RDTH-031-30021	RDRY-704-00109	5
0.3732 - 0.3933	9.48 - 9.99	1	<b>RDKH-210-00948</b>	<b>RDKH-110-00948</b>	RDCH-011-10024	RDTH-031-10024	RDRY-704-00109	5
0.3732 - 0.3933	9.48 - 9.99	2	<b>RDKH-220-00948</b>	<b>RDKH-120-00948</b>	RDCH-011-20024	RDTH-031-20024	RDRY-704-00109	5
0.3732 - 0.3933	9.48 - 9.99	3	<b>RDKH-230-00948</b>	<b>RDKH-130-00948</b>	RDCH-011-30024	RDTH-031-30024	RDRY-704-00109	5
0.3902 - 0.4102	9.91 - 10.42	1	<b>RDKH-210-00991</b>	<b>RDKH-110-00991</b>	RDCH-011-10025	RDTH-031-10025	RDRY-704-00109	5
0.3902 - 0.4102	9.91 - 10.42	2	<b>RDKH-220-00991</b>	<b>RDKH-120-00991</b>	RDCH-011-20025	RDTH-031-20025	RDRY-704-00109	5
0.3902 - 0.4102	9.91 - 10.42	3	<b>RDKH-230-00991</b>	<b>RDKH-130-00991</b>	RDCH-011-30025	RDTH-031-30025	RDRY-704-00109	5
0.4051 - 0.4252	10.29 - 10.80	1	<b>RDKH-210-01029</b>	<b>RDKH-110-01029</b>	RDCH-011-10026	RDTH-031-10024	RDRY-704-00125	5
0.4051 - 0.4252	10.29 - 10.80	2	<b>RDKH-220-01029</b>	<b>RDKH-120-01029</b>	RDCH-011-20026	RDTH-031-20024	RDRY-704-00125	5
0.4051 - 0.4252	10.29 - 10.80	3	<b>RDKH-230-01029</b>	<b>RDKH-130-01029</b>	RDCH-011-30026	RDTH-031-30024	RDRY-704-00125	5
0.4217 - 0.4413	10.71 - 11.21	1	<b>RDKH-210-01071</b>	<b>RDKH-110-01071</b>	RDCH-011-10027	RDTH-031-10025	RDRY-704-00125	5
0.4217 - 0.4413	10.71 - 11.21	2	<b>RDKH-220-01071</b>	<b>RDKH-120-01071</b>	RDCH-011-20027	RDTH-031-20025	RDRY-704-00125	5
0.4217 - 0.4413	10.71 - 11.21	3	<b>RDKH-230-01071</b>	<b>RDKH-130-01071</b>	RDCH-011-30027	RDTH-031-30025	RDRY-704-00125	5
0.4374 - 0.4571	11.11 - 11.61	1	<b>RDKH-210-01111</b>	<b>RDKH-110-01111</b>	RDCH-011-10028	RDTH-031-10028	RDRY-704-00125	5
0.4374 - 0.4571	11.11 - 11.61	2	<b>RDKH-220-01111</b>	<b>RDKH-120-01111</b>	RDCH-011-20028	RDTH-031-20028	RDRY-704-00125	5
0.4374 - 0.4571	11.11 - 11.61	3	<b>RDKH-230-01111</b>	<b>RDKH-130-01111</b>	RDCH-011-30028	RDTH-031-30028	RDRY-704-00125	5
0.4512 - 0.4709	11.46 - 11.96	1	<b>RDKH-210-01146</b>	<b>RDKH-110-01146</b>	RDCH-011-10029	RDTH-031-10024	RDRY-704-00148	5
0.4512 - 0.4709	11.46 - 11.96	2	<b>RDKH-220-01146</b>	<b>RDKH-120-01146</b>	RDCH-011-20029	RDTH-031-20024	RDRY-704-00148	5
0.4512 - 0.4709	11.46 - 11.96	3	<b>RDKH-230-01146</b>	<b>RDKH-130-01146</b>	RDCH-011-30029	RDTH-031-30024	RDRY-704-00148	5
0.4681 - 0.4878	11.89 - 12.39	1	<b>RDKH-210-01189</b>	<b>RDKH-110-01189</b>	RDCH-011-10030	RDTH-031-10025	RDRY-704-00148	5
0.4681 - 0.4878	11.89 - 12.39	2	<b>RDKH-220-01189</b>	<b>RDKH-120-01189</b>	RDCH-011-20030	RDTH-031-20025	RDRY-704-00148	5
0.4681 - 0.4878	11.89 - 12.39	3	<b>RDKH-230-01189</b>	<b>RDKH-130-01189</b>	RDCH-011-30030	RDTH-031-30025	RDRY-704-00148	5
0.4831 - 0.5028	12.27 - 12.77	1	<b>RDKH-210-01227</b>	<b>RDKH-110-01227</b>	RDCH-011-10031	RDTH-031-10028	RDRY-704-00148	5
0.4831 - 0.5028	12.27 - 12.77	2	<b>RDKH-220-01227</b>	<b>RDKH-120-01227</b>	RDCH-011-20031	RDTH-031-20028	RDRY-704-00148	5
0.4831 - 0.5028	12.27 - 12.77	3	<b>RDKH-230-01227</b>	<b>RDKH-130-01227</b>	RDCH-011-30031	RDTH-031-30028	RDRY-704-00148	5

注释：每种滚筒抛光工具都装配有锁紧器、锥体和辊。

D : 42 - 45

D : 40 - 41

D : 38

说明参见: 1

# 滚筒抛光工具 | 盲孔

H系列 | 直径范围：0.2319" - 0.5028" (5.89 mm - 12.77 mm)

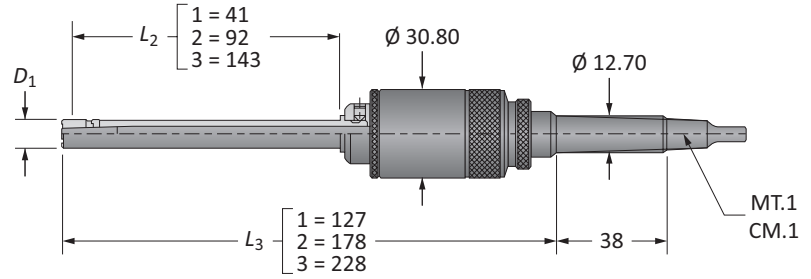

D <sub>1</sub>		L	零件号*		备件			
英制 (in)	公制 (mm)		包含莫氏锥柄的总成	包含直柄的总成	锁紧器	锥体**	辊	辊数量
0.2319 - 0.2524	5.89 - 6.41	1	RSKH-210-xxxxx	RSKH-110-xxxxx	RSCH-015-10015	RSTH-03x-10012	RSRY-708-00086	3
0.2319 - 0.2524	5.89 - 6.41	2	RSKH-220-xxxxx	RSKH-120-xxxxx	RSCH-015-20015	RSTH-03x-20012	RSRY-708-00086	3
0.2319 - 0.2524	5.89 - 6.41	3	RSKH-230-xxxxx	RSKH-130-xxxxx	RSCH-015-30015	RSTH-03x-30012	RSRY-708-00086	3
0.2484 - 0.2681	6.31 - 6.81	1	RSKH-210-xxxxx	RSKH-110-xxxxx	RSCH-015-10016	RSTH-03x-10013	RSRY-708-00086	3
0.2484 - 0.2681	6.31 - 6.81	2	RSKH-220-xxxxx	RSKH-120-xxxxx	RSCH-015-20016	RSTH-03x-20013	RSRY-708-00086	3
0.2484 - 0.2681	6.31 - 6.81	3	RSKH-230-xxxxx	RSKH-130-xxxxx	RSCH-015-30016	RSTH-03x-30013	RSRY-708-00086	3
0.2642 - 0.2839	6.71 - 7.21	1	RSKH-210-xxxxx	RSKH-110-xxxxx	RSCH-015-10017	RSTH-03x-10015	RSRY-708-00086	3
0.2642 - 0.2839	6.71 - 7.21	2	RSKH-220-xxxxx	RSKH-120-xxxxx	RSCH-015-20017	RSTH-03x-20015	RSRY-708-00086	3
0.2642 - 0.2839	6.71 - 7.21	3	RSKH-230-xxxxx	RSKH-130-xxxxx	RSCH-015-30017	RSTH-03x-30015	RSRY-708-00086	3
0.2803 - 0.3000	7.12 - 7.62	1	RSKH-210-xxxxx	RSKH-110-xxxxx	RSCH-015-10018	RSTH-03x-10017	RSRY-708-00086	3
0.2803 - 0.3000	7.12 - 7.62	2	RSKH-220-xxxxx	RSKH-120-xxxxx	RSCH-015-20018	RSTH-03x-20017	RSRY-708-00086	3
0.2803 - 0.3000	7.12 - 7.62	3	RSKH-230-xxxxx	RSKH-130-xxxxx	RSCH-015-30018	RSTH-03x-30017	RSRY-708-00086	3
0.2945 - 0.3142	7.48 - 7.98	1	RSKH-210-xxxxx	RSKH-110-xxxxx	RSCH-015-10019	RSTH-03x-10019	RSRY-708-00086	3
0.2945 - 0.3142	7.48 - 7.98	2	RSKH-220-xxxxx	RSKH-120-xxxxx	RSCH-015-20019	RSTH-03x-20019	RSRY-708-00086	3
0.2945 - 0.3142	7.48 - 7.98	3	RSKH-230-xxxxx	RSKH-130-xxxxx	RSCH-015-30019	RSTH-03x-30019	RSRY-708-00086	3
0.3102 - 0.3299	7.88 - 8.38	1	RSKH-210-xxxxx	RSKH-110-xxxxx	RSCH-015-10020	RSTH-03x-10021	RSRY-708-00086	3
0.3102 - 0.3299	7.88 - 8.38	2	RSKH-220-xxxxx	RSKH-120-xxxxx	RSCH-015-20020	RSTH-03x-20021	RSRY-708-00086	3
0.3102 - 0.3299	7.88 - 8.38	3	RSKH-230-xxxxx	RSKH-130-xxxxx	RSCH-015-30020	RSTH-03x-30021	RSRY-708-00086	3
0.3260 - 0.3461	8.28 - 8.79	1	RSKH-210-xxxxx	RSKH-110-xxxxx	RSCH-015-10021	RSTH-03x-10024	RSRY-708-00086	3
0.3260 - 0.3461	8.28 - 8.79	2	RSKH-220-xxxxx	RSKH-120-xxxxx	RSCH-015-20021	RSTH-03x-20024	RSRY-708-00086	3
0.3260 - 0.3461	8.28 - 8.79	3	RSKH-230-xxxxx	RSKH-130-xxxxx	RSCH-015-30021	RSTH-03x-30024	RSRY-708-00086	3
0.3410 - 0.3606	8.66 - 9.16	1	RSKH-210-xxxxx	RSKH-110-xxxxx	RSCH-015-10022	RSTH-03x-10015	RSRY-708-00125	3
0.3410 - 0.3606	8.66 - 9.16	2	RSKH-220-xxxxx	RSKH-120-xxxxx	RSCH-015-20022	RSTH-03x-20015	RSRY-708-00125	3
0.3410 - 0.3606	8.66 - 9.16	3	RSKH-230-xxxxx	RSKH-130-xxxxx	RSCH-015-30022	RSTH-03x-30015	RSRY-708-00125	3
0.3567 - 0.3768	9.06 - 9.57	1	RSKH-210-xxxxx	RSKH-110-xxxxx	RSCH-015-10023	RSTH-03x-10017	RSRY-708-00125	3
0.3567 - 0.3768	9.06 - 9.57	2	RSKH-220-xxxxx	RSKH-120-xxxxx	RSCH-015-20023	RSTH-03x-20017	RSRY-708-00125	3
0.3567 - 0.3768	9.06 - 9.57	3	RSKH-230-xxxxx	RSKH-130-xxxxx	RSCH-015-30023	RSTH-03x-30017	RSRY-708-00125	3

\*xxxxx = 指示包含2位小数的公制待抛光尺寸 (例如直径为10.25 mm, 带MT.1柄的短系列滚筒抛光工具: RSKH-210-01025)。

\*\*x = 一个在2 - 8的范围内变化的数字, 具体取决于精确的待抛光直径。有关 "x" 值的正确识别, 请参见第D: 6页。

注释: 每种滚筒抛光工具都装配有锁紧器、锥体和辊。

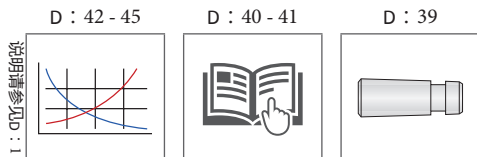



# 滚筒抛光工具 | 盲孔 (续)

H系列 | 直径范围 : 0.2319" - 0.5028" (5.89 mm - 12.77 mm)

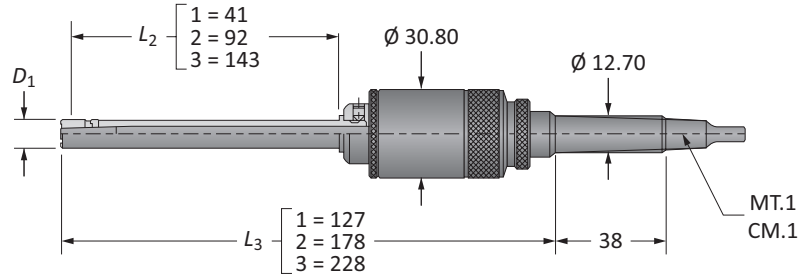

$D_1$		L	零件号*		备件			
英制 (in)	公制 (mm)		包含莫氏锥柄的总成	包含直柄的总成	锁紧器	锥体**	辊	辊数量
0.3732 - 0.3933	9.48 - 9.99	1	RSKH-210-xxxxx	RSKH-110-xxxxx	RSCH-015-10024	RSTH-03x-10019	RSRY-708-00125	3
0.3732 - 0.3933	9.48 - 9.99	2	RSKH-220-xxxxx	RSKH-120-xxxxx	RSCH-015-20024	RSTH-03x-20019	RSRY-708-00125	3
0.3732 - 0.3933	9.48 - 9.99	3	RSKH-230-xxxxx	RSKH-130-xxxxx	RSCH-015-30024	RSTH-03x-30019	RSRY-708-00125	3
0.3902 - 0.4102	9.91 - 10.42	1	RSKH-210-xxxxx	RSKH-110-xxxxx	RSCH-015-10025	RSTH-03x-10021	RSRY-708-00125	3
0.3902 - 0.4102	9.91 - 10.42	2	RSKH-220-xxxxx	RSKH-120-xxxxx	RSCH-015-20025	RSTH-03x-20021	RSRY-708-00125	3
0.3902 - 0.4102	9.91 - 10.42	3	RSKH-230-xxxxx	RSKH-130-xxxxx	RSCH-015-30025	RSTH-03x-30021	RSRY-708-00125	3
0.4051 - 0.4252	10.29 - 10.80	1	RSKH-210-xxxxx	RSKH-110-xxxxx	RSCH-015-10026	RSTH-03x-10024	RSRY-708-00125	3
0.4051 - 0.4252	10.29 - 10.80	2	RSKH-220-xxxxx	RSKH-120-xxxxx	RSCH-015-20026	RSTH-03x-20024	RSRY-708-00125	3
0.4051 - 0.4252	10.29 - 10.80	3	RSKH-230-xxxxx	RSKH-130-xxxxx	RSCH-015-30026	RSTH-03x-30024	RSRY-708-00125	3
0.4217 - 0.4413	10.71 - 11.21	1	RSKH-210-xxxxx	RSKH-110-xxxxx	RSCH-015-10027	RSTH-03x-10025	RSRY-708-00125	3
0.4217 - 0.4413	10.71 - 11.21	2	RSKH-220-xxxxx	RSKH-120-xxxxx	RSCH-015-20027	RSTH-03x-20025	RSRY-708-00125	3
0.4217 - 0.4413	10.71 - 11.21	3	RSKH-230-xxxxx	RSKH-130-xxxxx	RSCH-015-30027	RSTH-03x-30025	RSRY-708-00125	3
0.4374 - 0.4571	11.11 - 11.61	1	RSKH-210-xxxxx	RSKH-110-xxxxx	RSCH-015-10028	RSTH-03x-10028	RSRY-708-00125	3
0.4374 - 0.4571	11.11 - 11.61	2	RSKH-220-xxxxx	RSKH-120-xxxxx	RSCH-015-20028	RSTH-03x-20028	RSRY-708-00125	3
0.4374 - 0.4571	11.11 - 11.61	3	RSKH-230-xxxxx	RSKH-130-xxxxx	RSCH-015-30028	RSTH-03x-30028	RSRY-708-00125	3
0.4512 - 0.4709	11.46 - 11.96	1	RSKH-210-xxxxx	RSKH-110-xxxxx	RSCH-015-10029	RSTH-03x-10021	RSRY-708-00156	3
0.4512 - 0.4709	11.46 - 11.96	2	RSKH-220-xxxxx	RSKH-120-xxxxx	RSCH-015-20029	RSTH-03x-20021	RSRY-708-00156	3
0.4512 - 0.4709	11.46 - 11.96	3	RSKH-230-xxxxx	RSKH-130-xxxxx	RSCH-015-30029	RSTH-03x-30021	RSRY-708-00156	3
0.4681 - 0.4878	11.89 - 12.39	1	RSKH-210-xxxxx	RSKH-110-xxxxx	RSCH-015-10030	RSTH-03x-10024	RSRY-708-00156	3
0.4681 - 0.4878	11.89 - 12.39	2	RSKH-220-xxxxx	RSKH-120-xxxxx	RSCH-015-20030	RSTH-03x-20024	RSRY-708-00156	3
0.4681 - 0.4878	11.89 - 12.39	3	RSKH-230-xxxxx	RSKH-130-xxxxx	RSCH-015-30030	RSTH-03x-30024	RSRY-708-00156	3
0.4831 - 0.5028	12.27 - 12.77	1	RSKH-210-xxxxx	RSKH-110-xxxxx	RSCH-015-10031	RSTH-03x-10025	RSRY-708-00156	3
0.4831 - 0.5028	12.27 - 12.77	2	RSKH-220-xxxxx	RSKH-120-xxxxx	RSCH-015-20031	RSTH-03x-20025	RSRY-708-00156	3
0.4831 - 0.5028	12.27 - 12.77	3	RSKH-230-xxxxx	RSKH-130-xxxxx	RSCH-015-30031	RSTH-03x-30025	RSRY-708-00156	3

\*xxxxx = 指示包含2位小数的公制待抛光尺寸 (例如直径为10.25 mm, 带MT.1柄的短系列滚筒抛光工具: RSKH-210-01025)。

\*\*x = 一个在2 - 8的范围内变化的数字, 具体取决于精确的待抛光直径。有关 "x" 值的正确识别, 请参见第D : 6页。

注释: 每种滚筒抛光工具都装配有锁紧器、锥体和辊。

D : 42 - 45      D : 40 - 41      D : 39

说明请参见D : 1

H  
A  
B  
C  
D  
E  
X

钻削  
镗孔  
抛光  
螺纹加工  
特殊应用

## 滚筒抛光工具 | 通孔

系列 | 直径范围：0.4976" - 0.6634" (12.64 mm - 16.85 mm)

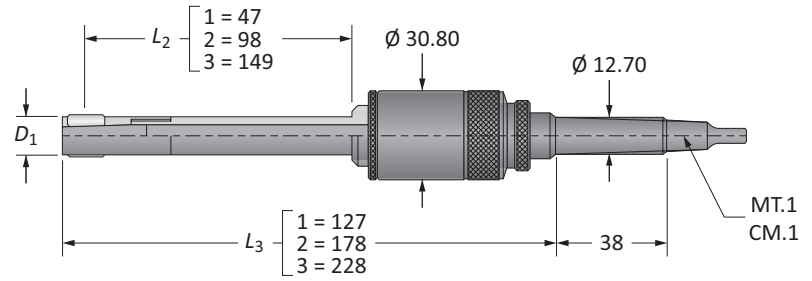

$D_1$		$L$	零件号		备件			
英制 (in)	公制 (mm)		包含莫氏锥柄的总成	包含直柄的总成	锁紧器	锥体	辊	辊数量
0.4976 - 0.5315	12.64 - 13.50	1	<b>RDKI-210-01264</b>	<b>RDKI-110-01264</b>	RDCI-400-00500	RDTI-031-10032	RDRY-704-00156	5
0.4976 - 0.5315	12.64 - 13.50	2	<b>RDKI-220-01264</b>	<b>RDKI-120-01264</b>	RDCI-400-00500	RDTI-031-20032	RDRY-704-00156	5
0.4976 - 0.5315	12.64 - 13.50	3	<b>RDKI-230-01264</b>	<b>RDKI-130-01264</b>	RDCI-400-00500	RDTI-031-30032	RDRY-704-00156	5
0.5295 - 0.5689	13.45 - 14.45	1	<b>RDKI-210-01345</b>	<b>RDKI-110-01345</b>	RDCI-400-00531	RDTI-031-10034	RDRY-704-00156	5
0.5295 - 0.5689	13.45 - 14.45	2	<b>RDKI-220-01345</b>	<b>RDKI-120-01345</b>	RDCI-400-00531	RDTI-031-20034	RDRY-704-00156	5
0.5295 - 0.5689	13.45 - 14.45	3	<b>RDKI-230-01345</b>	<b>RDKI-130-01345</b>	RDCI-400-00531	RDTI-031-30034	RDRY-704-00156	5
0.5610 - 0.6004	14.25 - 15.25	1	<b>RDKI-210-01425</b>	<b>RDKI-110-01425</b>	RDCI-400-00562	RDTI-031-10034	RDRY-704-00172	5
0.5610 - 0.6004	14.25 - 15.25	2	<b>RDKI-220-01425</b>	<b>RDKI-120-01425</b>	RDCI-400-00562	RDTI-031-20034	RDRY-704-00172	5
0.5610 - 0.6004	14.25 - 15.25	3	<b>RDKI-230-01425</b>	<b>RDKI-130-01425</b>	RDCI-400-00562	RDTI-031-30034	RDRY-704-00172	5
0.5925 - 0.6319	15.05 - 16.05	1	<b>RDKI-210-01505</b>	<b>RDKI-110-01505</b>	RDCI-400-00593	RDTI-031-10038	RDRY-704-00172	5
0.5925 - 0.6319	15.05 - 16.05	2	<b>RDKI-220-01505</b>	<b>RDKI-120-01505</b>	RDCI-400-00593	RDTI-031-20038	RDRY-704-00172	5
0.5925 - 0.6319	15.05 - 16.05	3	<b>RDKI-230-01505</b>	<b>RDKI-130-01505</b>	RDCI-400-00593	RDTI-031-30038	RDRY-704-00172	5
0.6240 - 0.6634	15.85 - 16.85	1	<b>RDKI-210-01585</b>	<b>RDKI-110-01585</b>	RDCI-400-00625	RDTI-031-10038	RDRY-701-00187	5
0.6240 - 0.6634	15.85 - 16.85	2	<b>RDKI-220-01585</b>	<b>RDKI-120-01585</b>	RDCI-400-00625	RDTI-031-20038	RDRY-701-00187	5
0.6240 - 0.6634	15.85 - 16.85	3	<b>RDKI-230-01585</b>	<b>RDKI-130-01585</b>	RDCI-400-00625	RDTI-031-30038	RDRY-701-00187	5

注释：每种滚筒抛光工具都装配有锁紧器、锥体和辊。

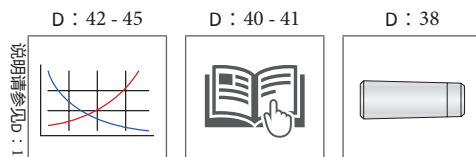



# 滚筒抛光工具 | 盲孔

I系列 | 直径范围：0.4976" - 0.6634" (12.64 mm - 16.85 mm)

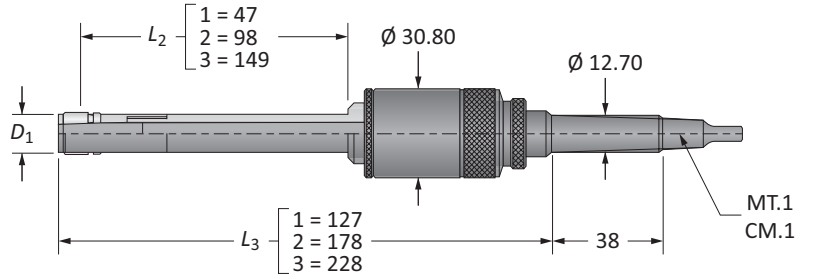

D <sub>1</sub>		L	零件号*		备件			
英制 (in)	公制 (mm)		包含莫氏锥柄的总成	包含直柄的总成	锁紧器	锥体**	辊	辊数量
0.4976 - 0.5315	12.64 - 13.50	1	RSKI-210-xxxxx	RSKI-110-xxxxx	RSCI-400-00500	RSTI-03X-10032	RSRY-708-00156	5
0.4976 - 0.5315	12.64 - 13.50	2	RSKI-220-xxxxx	RSKI-120-xxxxx	RSCI-400-00500	RSTI-03X-20032	RSRY-708-00156	5
0.4976 - 0.5315	12.64 - 13.50	3	RSKI-230-xxxxx	RSKI-130-xxxxx	RSCI-400-00500	RSTI-03X-30032	RSRY-708-00156	5
0.5295 - 0.5689	13.45 - 14.45	1	RSKI-210-xxxxx	RSKI-110-xxxxx	RSCI-400-00531	RSTI-03X-10034	RSRY-708-00156	5
0.5295 - 0.5689	13.45 - 14.45	2	RSKI-220-xxxxx	RSKI-120-xxxxx	RSCI-400-00531	RSTI-03X-20034	RSRY-708-00156	5
0.5295 - 0.5689	13.45 - 14.45	3	RSKI-230-xxxxx	RSKI-130-xxxxx	RSCI-400-00531	RSTI-03X-30034	RSRY-708-00156	5
0.5610 - 0.6004	14.25 - 15.25	1	RSKI-210-xxxxx	RSKI-110-xxxxx	RSCI-400-00562	RSTI-03X-10034	RSRY-708-00172	5
0.5610 - 0.6004	14.25 - 15.25	2	RSKI-220-xxxxx	RSKI-120-xxxxx	RSCI-400-00562	RSTI-03X-20034	RSRY-708-00172	5
0.5610 - 0.6004	14.25 - 15.25	3	RSKI-230-xxxxx	RSKI-130-xxxxx	RSCI-400-00562	RSTI-03X-30034	RSRY-708-00172	5
0.5925 - 0.6319	15.05 - 16.05	1	RSKI-210-xxxxx	RSKI-110-xxxxx	RSCI-400-00593	RSTI-03X-10038	RSRY-708-00172	5
0.5925 - 0.6319	15.05 - 16.05	2	RSKI-220-xxxxx	RSKI-120-xxxxx	RSCI-400-00593	RSTI-03X-20038	RSRY-708-00172	5
0.5925 - 0.6319	15.05 - 16.05	3	RSKI-230-xxxxx	RSKI-130-xxxxx	RSCI-400-00593	RSTI-03X-30038	RSRY-708-00172	5
0.6240 - 0.6634	15.85 - 16.85	1	RSKI-210-xxxxx	RSKI-110-xxxxx	RSCI-400-00625	RSTI-03X-10038	RSRY-708-00187	5
0.6240 - 0.6634	15.85 - 16.85	2	RSKI-220-xxxxx	RSKI-120-xxxxx	RSCI-400-00625	RSTI-03X-20038	RSRY-708-00187	5
0.6240 - 0.6634	15.85 - 16.85	3	RSKI-230-xxxxx	RSKI-130-xxxxx	RSCI-400-00625	RSTI-03X-30038	RSRY-708-00187	5

\*xxxxx = 指示包含2位小数的公制待抛光尺寸 (例如直径为14.00 mm, 带MT.1柄的长系列滚筒抛光工具: RSKI-230-01400)。

\*\*x = 一个在2-8的范围内变化的数字, 具体取决于精确的待抛光直径。有关“x”值的正确识别, 请参见第D: 6页。

注释: 每种滚筒抛光工具都装配有锁紧器、锥体和辊。

D : 42 - 45      D : 40 - 41      D : 39

说明请参见D : 1

A

钻削

B

镗孔

C

铰孔

D

抛光

E

螺纹加工

X

特殊应用

## 滚筒抛光工具 | 通孔

K系列 | 直径范围：0.6535" - 0.9740" (16.60 mm - 24.74 mm)

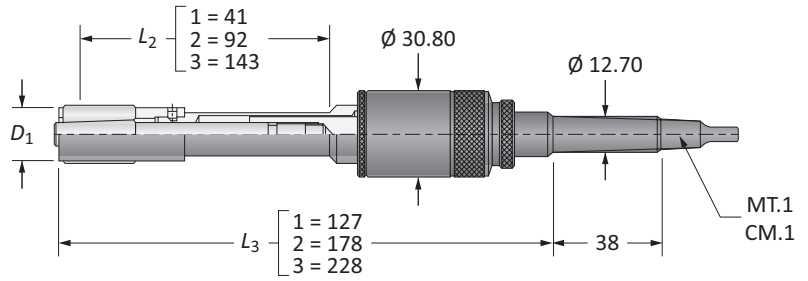

D <sub>1</sub>		L	零件号		备件			
英制 (in)	公制 (mm)		包含莫氏锥柄的总成	包含直柄的总成	锁紧器	锥体	辊	辊数量
0.6535 - 0.6933	16.60 - 17.61	1	<b>RDKK-210-01660</b>	<b>RDKK-110-01660</b>	RDCK-011-00042	RDTK-031-00042	RDRY-701-00187	5
0.6535 - 0.6933	16.60 - 17.61	2	<b>RDKK-220-01660</b>	<b>RDKK-120-01660</b>	RDCK-011-00042	RDTK-031-00042	RDRY-701-00187	5
0.6535 - 0.6933	16.60 - 17.61	3	<b>RDKK-230-01660</b>	<b>RDKK-130-01660</b>	RDCK-011-00042	RDTK-031-00042	RDRY-701-00187	5
0.6850 - 0.7240	17.40 - 18.39	1	<b>RDKK-210-01740</b>	<b>RDKK-110-01740</b>	RDCK-011-00044	RDTK-031-00044	RDRY-701-00187	5
0.6850 - 0.7240	17.40 - 18.39	2	<b>RDKK-220-01740</b>	<b>RDKK-120-01740</b>	RDCK-011-00044	RDTK-031-00044	RDRY-701-00187	5
0.6850 - 0.7240	17.40 - 18.39	3	<b>RDKK-230-01740</b>	<b>RDKK-130-01740</b>	RDCK-011-00044	RDTK-031-00044	RDRY-701-00187	5
0.7161 - 0.7551	18.19 - 19.18	1	<b>RDKK-210-01819</b>	<b>RDKK-110-01819</b>	RDCK-011-00046	RDTK-031-00042	RDRY-701-00218	5
0.7161 - 0.7551	18.19 - 19.18	2	<b>RDKK-220-01819</b>	<b>RDKK-120-01819</b>	RDCK-011-00046	RDTK-031-00042	RDRY-701-00218	5
0.7161 - 0.7551	18.19 - 19.18	3	<b>RDKK-230-01819</b>	<b>RDKK-130-01819</b>	RDCK-011-00046	RDTK-031-00042	RDRY-701-00218	5
0.7465 - 0.7870	18.96 - 19.99	1	<b>RDKK-210-01896</b>	<b>RDKK-110-01896</b>	RDCK-011-00048	RDTK-031-00044	RDRY-701-00218	5
0.7465 - 0.7870	18.96 - 19.99	2	<b>RDKK-220-01896</b>	<b>RDKK-120-01896</b>	RDCK-011-00048	RDTK-031-00044	RDRY-701-00218	5
0.7465 - 0.7870	18.96 - 19.99	3	<b>RDKK-230-01896</b>	<b>RDKK-130-01896</b>	RDCK-011-00048	RDTK-031-00044	RDRY-701-00218	5
0.7772 - 0.8177	19.74 - 20.77	1	<b>RDKK-210-01974</b>	<b>RDKK-110-01974</b>	RDCK-011-00050	RDTK-031-00050	RDRY-701-00218	5
0.7772 - 0.8177	19.74 - 20.77	2	<b>RDKK-220-01974</b>	<b>RDKK-120-01974</b>	RDCK-011-00050	RDTK-031-00050	RDRY-701-00218	5
0.7772 - 0.8177	19.74 - 20.77	3	<b>RDKK-230-01974</b>	<b>RDKK-130-01974</b>	RDCK-011-00050	RDTK-031-00050	RDRY-701-00218	5
0.8079 - 0.8492	20.52 - 21.57	1	<b>RDKK-210-02052</b>	<b>RDKK-110-02052</b>	RDCK-011-00052	RDTK-031-00052	RDRY-701-00218	5
0.8079 - 0.8492	20.52 - 21.57	2	<b>RDKK-220-02052</b>	<b>RDKK-120-02052</b>	RDCK-011-00052	RDTK-031-00052	RDRY-701-00218	5
0.8079 - 0.8492	20.52 - 21.57	3	<b>RDKK-230-02052</b>	<b>RDKK-130-02052</b>	RDCK-011-00052	RDTK-031-00052	RDRY-701-00218	5
0.8390 - 0.8799	21.31 - 22.35	1	<b>RDKK-210-02131</b>	<b>RDKK-110-02131</b>	RDCK-011-00054	RDTK-031-00054	RDRY-701-00218	5
0.8390 - 0.8799	21.31 - 22.35	2	<b>RDKK-220-02131</b>	<b>RDKK-120-02131</b>	RDCK-011-00054	RDTK-031-00054	RDRY-701-00218	5
0.8390 - 0.8799	21.31 - 22.35	3	<b>RDKK-230-02131</b>	<b>RDKK-130-02131</b>	RDCK-011-00054	RDTK-031-00054	RDRY-701-00218	5
0.8713 - 0.9118	22.13 - 23.16	1	<b>RDKK-210-02213</b>	<b>RDKK-110-02213</b>	RDCK-011-00056	RDTK-031-00050	RDRY-701-00265	5
0.8713 - 0.9118	22.13 - 23.16	2	<b>RDKK-220-02213</b>	<b>RDKK-120-02213</b>	RDCK-011-00056	RDTK-031-00050	RDRY-701-00265	5
0.8713 - 0.9118	22.13 - 23.16	3	<b>RDKK-230-02213</b>	<b>RDKK-130-02213</b>	RDCK-011-00056	RDTK-031-00050	RDRY-701-00265	5
0.9020 - 0.9433	22.91 - 23.96	1	<b>RDKK-210-02291</b>	<b>RDKK-110-02291</b>	RDCK-011-00058	RDTK-031-00052	RDRY-701-00265	5
0.9020 - 0.9433	22.91 - 23.96	2	<b>RDKK-220-02291</b>	<b>RDKK-120-02291</b>	RDCK-011-00058	RDTK-031-00052	RDRY-701-00265	5
0.9020 - 0.9433	22.91 - 23.96	3	<b>RDKK-230-02291</b>	<b>RDKK-130-02291</b>	RDCK-011-00058	RDTK-031-00052	RDRY-701-00265	5
0.9331 - 0.9740	23.70 - 24.74	1	<b>RDKK-210-02370</b>	<b>RDKK-110-02370</b>	RDCK-011-00060	RDTK-031-00054	RDRY-701-00265	5
0.9331 - 0.9740	23.70 - 24.74	2	<b>RDKK-220-02370</b>	<b>RDKK-120-02370</b>	RDCK-011-00060	RDTK-031-00054	RDRY-701-00265	5
0.9331 - 0.9740	23.70 - 24.74	3	<b>RDKK-230-02370</b>	<b>RDKK-130-02370</b>	RDCK-011-00060	RDTK-031-00054	RDRY-701-00265	5

注释：每种滚筒抛光工具都装配有锁紧器、锥体和辊。

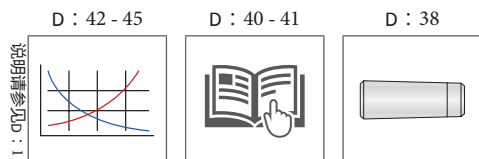





# 滚筒抛光工具 | 盲孔

k系列 | 直径范围 : 0.6535" - 0.9740" (16.60 mm - 24.74 mm)

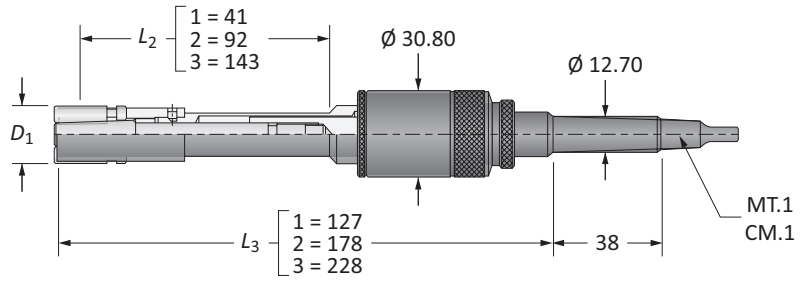

\$D_1\$		\$L\$	零件号*		备件			
英制 (in)	公制 (mm)		包含莫氏锥柄的总成	包含直柄的总成	锁紧器	锥体**	辊	辊数量
0.6535 - 0.6933	16.60 - 17.61	1	RSKK-210-xxxxx	RSKK-110-xxxxx	RSCK-015-00042	RSTK-03x-00042	RSRY-708-00187	5
0.6535 - 0.6933	16.60 - 17.61	2	RSKK-220-xxxxx	RSKK-120-xxxxx	RSCK-015-00042	RSTK-03x-00042	RSRY-708-00187	5
0.6535 - 0.6933	16.60 - 17.61	3	RSKK-230-xxxxx	RSKK-130-xxxxx	RSCK-015-00042	RSTK-03x-00042	RSRY-708-00187	5
0.6850 - 0.7240	17.40 - 18.39	1	RSKK-210-xxxxx	RSKK-110-xxxxx	RSCK-015-00044	RSTK-03x-00044	RSRY-708-00187	5
0.6850 - 0.7240	17.40 - 18.39	2	RSKK-220-xxxxx	RSKK-120-xxxxx	RSCK-015-00044	RSTK-03x-00044	RSRY-708-00187	5
0.6850 - 0.7240	17.40 - 18.39	3	RSKK-230-xxxxx	RSKK-130-xxxxx	RSCK-015-00044	RSTK-03x-00044	RSRY-708-00187	5
0.7161 - 0.7551	18.19 - 19.18	1	RSKK-210-xxxxx	RSKK-110-xxxxx	RSCK-015-00046	RSTK-03x-00042	RSRY-708-00218	5
0.7161 - 0.7551	18.19 - 19.18	2	RSKK-220-xxxxx	RSKK-120-xxxxx	RSCK-015-00046	RSTK-03x-00042	RSRY-708-00218	5
0.7161 - 0.7551	18.19 - 19.18	3	RSKK-230-xxxxx	RSKK-130-xxxxx	RSCK-015-00046	RSTK-03x-00042	RSRY-708-00218	5
0.7465 - 0.7870	18.96 - 19.99	1	RSKK-210-xxxxx	RSKK-110-xxxxx	RSCK-015-00048	RSTK-03x-00044	RSRY-708-00218	5
0.7465 - 0.7870	18.96 - 19.99	2	RSKK-220-xxxxx	RSKK-120-xxxxx	RSCK-015-00048	RSTK-03x-00044	RSRY-708-00218	5
0.7465 - 0.7870	18.96 - 19.99	3	RSKK-230-xxxxx	RSKK-130-xxxxx	RSCK-015-00048	RSTK-03x-00044	RSRY-708-00218	5
0.7772 - 0.8177	19.74 - 20.77	1	RSKK-210-xxxxx	RSKK-110-xxxxx	RSCK-015-00050	RSTK-03x-00050	RSRY-708-00218	5
0.7772 - 0.8177	19.74 - 20.77	2	RSKK-220-xxxxx	RSKK-120-xxxxx	RSCK-015-00050	RSTK-03x-00050	RSRY-708-00218	5
0.7772 - 0.8177	19.74 - 20.77	3	RSKK-230-xxxxx	RSKK-130-xxxxx	RSCK-015-00050	RSTK-03x-00050	RSRY-708-00218	5
0.8079 - 0.8492	20.52 - 21.57	1	RSKK-210-xxxxx	RSKK-110-xxxxx	RSCK-015-00052	RSTK-03x-00052	RSRY-708-00218	5
0.8079 - 0.8492	20.52 - 21.57	2	RSKK-220-xxxxx	RSKK-120-xxxxx	RSCK-015-00052	RSTK-03x-00052	RSRY-708-00218	5
0.8079 - 0.8492	20.52 - 21.57	3	RSKK-230-xxxxx	RSKK-130-xxxxx	RSCK-015-00052	RSTK-03x-00052	RSRY-708-00218	5
0.8390 - 0.8799	21.31 - 22.35	1	RSKK-210-xxxxx	RSKK-110-xxxxx	RSCK-015-00054	RSTK-03x-00054	RSRY-708-00218	5
0.8390 - 0.8799	21.31 - 22.35	2	RSKK-220-xxxxx	RSKK-120-xxxxx	RSCK-015-00054	RSTK-03x-00054	RSRY-708-00218	5
0.8390 - 0.8799	21.31 - 22.35	3	RSKK-230-xxxxx	RSKK-130-xxxxx	RSCK-015-00054	RSTK-03x-00054	RSRY-708-00218	5
0.8713 - 0.9118	22.13 - 23.16	1	RSKK-210-xxxxx	RSKK-110-xxxxx	RSCK-015-00056	RSTK-03x-00050	RSRY-708-00265	5
0.8713 - 0.9118	22.13 - 23.16	2	RSKK-220-xxxxx	RSKK-120-xxxxx	RSCK-015-00056	RSTK-03x-00050	RSRY-708-00265	5
0.8713 - 0.9118	22.13 - 23.16	3	RSKK-230-xxxxx	RSKK-130-xxxxx	RSCK-015-00056	RSTK-03x-00050	RSRY-708-00265	5
0.9020 - 0.9433	22.91 - 23.96	1	RSKK-210-xxxxx	RSKK-110-xxxxx	RSCK-015-00058	RSTK-03x-00052	RSRY-708-00265	5
0.9020 - 0.9433	22.91 - 23.96	2	RSKK-220-xxxxx	RSKK-120-xxxxx	RSCK-015-00058	RSTK-03x-00052	RSRY-708-00265	5
0.9020 - 0.9433	22.91 - 23.96	3	RSKK-230-xxxxx	RSKK-130-xxxxx	RSCK-015-00058	RSTK-03x-00052	RSRY-708-00265	5
0.9331 - 0.9740	23.70 - 24.74	1	RSKK-210-xxxxx	RSKK-110-xxxxx	RSCK-015-00060	RSTK-03x-00054	RSRY-708-00265	5
0.9331 - 0.9740	23.70 - 24.74	2	RSKK-220-xxxxx	RSKK-120-xxxxx	RSCK-015-00060	RSTK-03x-00054	RSRY-708-00265	5
0.9331 - 0.9740	23.70 - 24.74	3	RSKK-230-xxxxx	RSKK-130-xxxxx	RSCK-015-00060	RSTK-03x-00054	RSRY-708-00265	5

\*xxxxx = 指示包含2位小数的公制待抛光尺寸 (例如直径为20.00 mm, 带MT.1柄的标准系列滚筒抛光工具: RSKK-120-02000)。

\*\*x = 一个在2 - 8的范围内变化的数字, 具体取决于精确的待抛光直径。有关 "x" 值的正确识别, 请参见第D : 6页。

注释: 每种滚筒抛光工具都装配有锁紧器、锥体和辊。

D : 42 - 45      D : 40 - 41      D : 39

说明请参见D : 1

K  
A  
B  
C  
D  
E  
X

钻削  
镗孔  
抛光  
螺纹加工  
特殊应用

## 滚筒抛光工具 | 通孔

L系列 | 直径范围：0.9661" - 1.2268" (24.54 mm - 31.16 mm)

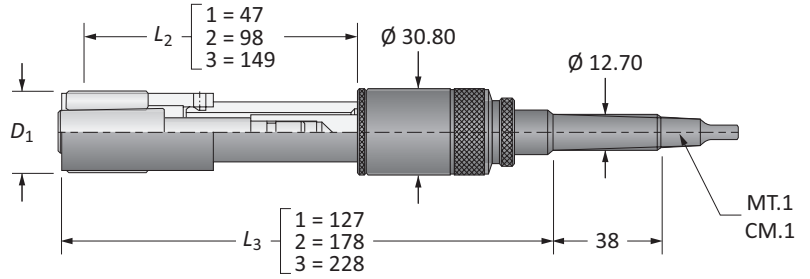

D <sub>1</sub>		L	零件号		备件			
英制 (in)	公制 (mm)		包含莫氏锥柄的总成	包含直柄的总成	锁紧器	锥体	辊	辊数量
0.9661 - 1.0075	24.54 - 25.59	1	<b>RDKL-210-02454</b>	<b>RDKL-110-02454</b>	RDCL-011-00062	RDTL-031-00062	RDRY-701-00265	5
0.9661 - 1.0075	24.54 - 25.59	2	<b>RDKL-220-02454</b>	<b>RDKL-120-02454</b>	RDCL-011-00062	RDTL-031-00062	RDRY-701-00265	5
0.9661 - 1.0075	24.54 - 25.59	3	<b>RDKL-230-02454</b>	<b>RDKL-130-02454</b>	RDCL-011-00062	RDTL-031-00062	RDRY-701-00265	5
0.9992 - 1.0402	25.38 - 26.42	1	<b>RDKL-210-02538</b>	<b>RDKL-110-02538</b>	RDCL-011-00064	RDTL-031-00064	RDRY-701-00265	7
0.9992 - 1.0402	25.38 - 26.42	2	<b>RDKL-220-02538</b>	<b>RDKL-120-02538</b>	RDCL-011-00064	RDTL-031-00064	RDRY-701-00265	7
0.9992 - 1.0402	25.38 - 26.42	3	<b>RDKL-230-02538</b>	<b>RDKL-130-02538</b>	RDCL-011-00064	RDTL-031-00064	RDRY-701-00265	7
1.0299 - 1.0709	26.16 - 27.20	1	<b>RDKL-210-02616</b>	<b>RDKL-110-02616</b>	RDCL-011-00066	RDTL-031-00066	RDRY-701-00265	7
1.0299 - 1.0709	26.16 - 27.20	2	<b>RDKL-220-02616</b>	<b>RDKL-120-02616</b>	RDCL-011-00066	RDTL-031-00066	RDRY-701-00265	7
1.0299 - 1.0709	26.16 - 27.20	3	<b>RDKL-230-02616</b>	<b>RDKL-130-02616</b>	RDCL-011-00066	RDTL-031-00066	RDRY-701-00265	7
1.0610 - 1.1024	26.95 - 28.00	1	<b>RDKL-210-02695</b>	<b>RDKL-110-02695</b>	RDCL-011-00068	RDTL-031-00068	RDRY-701-00265	7
1.0610 - 1.1024	26.95 - 28.00	2	<b>RDKL-220-02695</b>	<b>RDKL-120-02695</b>	RDCL-011-00068	RDTL-031-00068	RDRY-701-00265	7
1.0610 - 1.1024	26.95 - 28.00	3	<b>RDKL-230-02695</b>	<b>RDKL-130-02695</b>	RDCL-011-00068	RDTL-031-00068	RDRY-701-00265	7
1.0917 - 1.1327	27.73 - 28.77	1	<b>RDKL-210-02773</b>	<b>RDKL-110-02773</b>	RDCL-011-00070	RDTL-031-00070	RDRY-701-00265	7
1.0917 - 1.1327	27.73 - 28.77	2	<b>RDKL-220-02773</b>	<b>RDKL-120-02773</b>	RDCL-011-00070	RDTL-031-00070	RDRY-701-00265	7
1.0917 - 1.1327	27.73 - 28.77	3	<b>RDKL-230-02773</b>	<b>RDKL-130-02773</b>	RDCL-011-00070	RDTL-031-00070	RDRY-701-00265	7
1.1240 - 1.1650	28.55 - 29.59	1	<b>RDKL-210-02855</b>	<b>RDKL-110-02855</b>	RDCL-011-00072	RDTL-031-00066	RDRY-701-00312	7
1.1240 - 1.1650	28.55 - 29.59	2	<b>RDKL-220-02855</b>	<b>RDKL-120-02855</b>	RDCL-011-00072	RDTL-031-00066	RDRY-701-00312	7
1.1240 - 1.1650	28.55 - 29.59	3	<b>RDKL-230-02855</b>	<b>RDKL-130-02855</b>	RDCL-011-00072	RDTL-031-00066	RDRY-701-00312	7
1.1551 - 1.1965	29.34 - 30.39	1	<b>RDKL-210-02934</b>	<b>RDKL-110-02934</b>	RDCL-011-00074	RDTL-031-00068	RDRY-701-00312	7
1.1551 - 1.1965	29.34 - 30.39	2	<b>RDKL-220-02934</b>	<b>RDKL-120-02934</b>	RDCL-011-00074	RDTL-031-00068	RDRY-701-00312	7
1.1551 - 1.1965	29.34 - 30.39	3	<b>RDKL-230-02934</b>	<b>RDKL-130-02934</b>	RDCL-011-00074	RDTL-031-00068	RDRY-701-00312	7
1.1858 - 1.2268	30.12 - 31.16	1	<b>RDKL-210-03012</b>	<b>RDKL-110-03012</b>	RDCL-011-00076	RDTL-031-00070	RDRY-701-00312	7
1.1858 - 1.2268	30.12 - 31.16	2	<b>RDKL-220-03012</b>	<b>RDKL-120-03012</b>	RDCL-011-00076	RDTL-031-00070	RDRY-701-00312	7
1.1858 - 1.2268	30.12 - 31.16	3	<b>RDKL-230-03012</b>	<b>RDKL-130-03012</b>	RDCL-011-00076	RDTL-031-00070	RDRY-701-00312	7

注释：每种滚筒抛光工具都装配有锁紧器、锥体和辊。

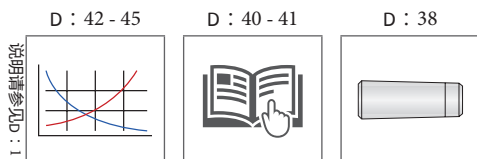



# 滚筒抛光工具 | 盲孔

L系列 | 直径范围：0.9661" - 1.2268" (24.54 mm - 31.16 mm)

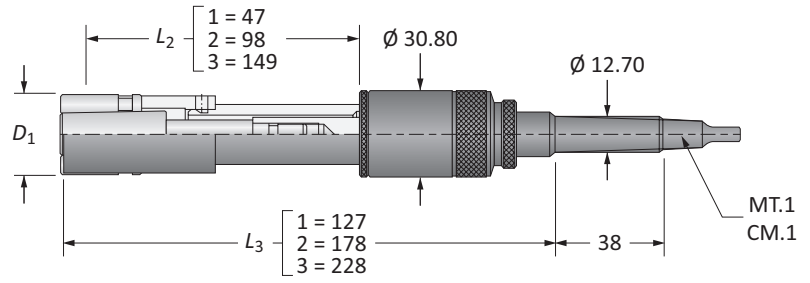

D <sub>1</sub>		L	零件号*		备件			
英制 (in)	公制 (mm)		包含莫氏锥柄的总成	包含直柄的总成	锁紧器	锥体**	辊	辊数量
0.9661 - 1.0075	24.54 - 25.59	1	RSKL-210-xxxxx	RSKL-110-xxxxx	RSCL-015-00062	RSTL-03x-00062	RSRY-708-00265	5
0.9661 - 1.0075	24.54 - 25.59	2	RSKL-220-xxxxx	RSKL-120-xxxxx	RSCL-015-00062	RSTL-03x-00062	RSRY-708-00265	5
0.9661 - 1.0075	24.54 - 25.59	3	RSKL-230-xxxxx	RSKL-130-xxxxx	RSCL-015-00062	RSTL-03x-00062	RSRY-708-00265	5
0.9992 - 1.0402	25.38 - 26.42	1	RSKL-210-xxxxx	RSKL-110-xxxxx	RSCL-015-00064	RSTL-03x-00064	RSRY-708-00265	5
0.9992 - 1.0402	25.38 - 26.42	2	RSKL-220-xxxxx	RSKL-120-xxxxx	RSCL-015-00064	RSTL-03x-00064	RSRY-708-00265	5
0.9992 - 1.0402	25.38 - 26.42	3	RSKL-230-xxxxx	RSKL-130-xxxxx	RSCL-015-00064	RSTL-03x-00064	RSRY-708-00265	5
1.0299 - 1.0709	26.16 - 27.20	1	RSKL-210-xxxxx	RSKL-110-xxxxx	RSCL-015-00066	RSTL-03x-00066	RSRY-708-00265	5
1.0299 - 1.0709	26.16 - 27.20	2	RSKL-220-xxxxx	RSKL-120-xxxxx	RSCL-015-00066	RSTL-03x-00066	RSRY-708-00265	5
1.0299 - 1.0709	26.16 - 27.20	3	RSKL-230-xxxxx	RSKL-130-xxxxx	RSCL-015-00066	RSTL-03x-00066	RSRY-708-00265	5
1.0610 - 1.1024	26.95 - 28.00	1	RSKL-210-xxxxx	RSKL-110-xxxxx	RSCL-015-00068	RSTL-03x-00068	RSRY-708-00265	5
1.0610 - 1.1024	26.95 - 28.00	2	RSKL-220-xxxxx	RSKL-120-xxxxx	RSCL-015-00068	RSTL-03x-00068	RSRY-708-00265	5
1.0610 - 1.1024	26.95 - 28.00	3	RSKL-230-xxxxx	RSKL-130-xxxxx	RSCL-015-00068	RSTL-03x-00068	RSRY-708-00265	5
1.0917 - 1.1327	27.73 - 28.77	1	RSKL-210-xxxxx	RSKL-110-xxxxx	RSCL-015-00070	RSTL-03x-00070	RSRY-708-00265	5
1.0917 - 1.1327	27.73 - 28.77	2	RSKL-220-xxxxx	RSKL-120-xxxxx	RSCL-015-00070	RSTL-03x-00070	RSRY-708-00265	5
1.0917 - 1.1327	27.73 - 28.77	3	RSKL-230-xxxxx	RSKL-130-xxxxx	RSCL-015-00070	RSTL-03x-00070	RSRY-708-00265	5
1.1240 - 1.1650	28.55 - 29.59	1	RSKL-210-xxxxx	RSKL-110-xxxxx	RSCL-015-00072	RSTL-03x-00066	RSRY-708-00312	5
1.1240 - 1.1650	28.55 - 29.59	2	RSKL-220-xxxxx	RSKL-120-xxxxx	RSCL-015-00072	RSTL-03x-00066	RSRY-708-00312	5
1.1240 - 1.1650	28.55 - 29.59	3	RSKL-230-xxxxx	RSKL-130-xxxxx	RSCL-015-00072	RSTL-03x-00066	RSRY-708-00312	5
1.1551 - 1.1965	29.34 - 30.39	1	RSKL-210-xxxxx	RSKL-110-xxxxx	RSCL-015-00074	RSTL-03x-00068	RSRY-708-00312	5
1.1551 - 1.1965	29.34 - 30.39	2	RSKL-220-xxxxx	RSKL-120-xxxxx	RSCL-015-00074	RSTL-03x-00068	RSRY-708-00312	5
1.1551 - 1.1965	29.34 - 30.39	3	RSKL-230-xxxxx	RSKL-130-xxxxx	RSCL-015-00074	RSTL-03x-00068	RSRY-708-00312	5
1.1858 - 1.2268	30.12 - 31.16	1	RSKL-210-xxxxx	RSKL-110-xxxxx	RSCL-015-00076	RSTL-03x-00070	RSRY-708-00312	5
1.1858 - 1.2268	30.12 - 31.16	2	RSKL-220-xxxxx	RSKL-120-xxxxx	RSCL-015-00076	RSTL-03x-00070	RSRY-708-00312	5
1.1858 - 1.2268	30.12 - 31.16	3	RSKL-230-xxxxx	RSKL-130-xxxxx	RSCL-015-00076	RSTL-03x-00070	RSRY-708-00312	5

\*xxxxx = 指示包含2位小数的公制待抛光尺寸 (例如直径为27.50 mm, 带MT.1柄的短系列滚筒抛光工具: RSKL-210-02750)。

\*\*x = 一个在2 - 8的范围内变化的数字, 具体取决于精确的待抛光直径。有关 "x" 值的正确识别, 请参见第D : 6页。

注释: 每种滚筒抛光工具都装配有锁紧器、锥体和辊。

D : 42 - 45

D : 40 - 41

D : 39

说明请参见D : 1

## 滚筒抛光工具 | 通孔

F系列 | 直径范围：0.9661" - 1.2268" (24.54 mm - 31.16 mm)

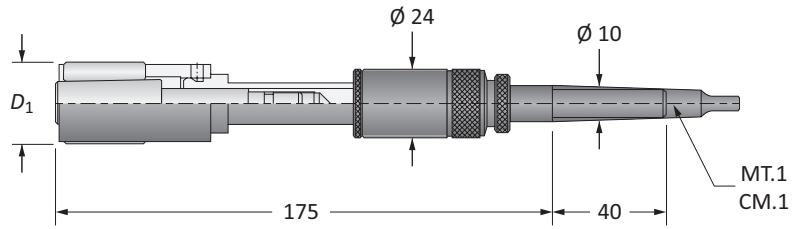

D <sub>1</sub>		零件号		备件			
英制 (in)	公制 (mm)	包含莫氏锥柄的总成	包含直柄的总成	锁紧器	锥体	辊	辊数量
0.9661 - 1.0075	24.54 - 25.59	<b>RDKF-200-02454</b>	<b>RDKF-100-02454</b>	RDCL-011-00062	RDTF-031-00062	RDRY-701-00265	5
0.9992 - 1.0402	25.38 - 26.42	<b>RDKF-200-02538</b>	<b>RDKF-100-02538</b>	RDCL-011-00064	RDTF-031-00064	RDRY-701-00265	7
1.0299 - 1.0709	26.16 - 27.20	<b>RDKF-200-02616</b>	<b>RDKF-100-02616</b>	RDCL-011-00066	RDTF-031-00066	RDRY-701-00265	7
1.0610 - 1.1024	26.95 - 28.00	<b>RDKF-200-02695</b>	<b>RDKF-100-02695</b>	RDCL-011-00068	RDTF-031-00068	RDRY-701-00265	7
1.0917 - 1.1327	27.73 - 28.77	<b>RDKF-200-02773</b>	<b>RDKF-100-02773</b>	RDCL-011-00070	RDTF-031-00070	RDRY-701-00265	7
1.1240 - 1.1650	28.55 - 29.59	<b>RDKF-200-02855</b>	<b>RDKF-100-02855</b>	RDCL-011-00072	RDTF-031-00066	RDRY-701-00312	7
1.1551 - 1.1965	29.34 - 30.39	<b>RDKF-200-02934</b>	<b>RDKF-100-02934</b>	RDCL-011-00074	RDTF-031-00068	RDRY-701-00312	7
1.1858 - 1.2268	30.12 - 31.16	<b>RDKF-200-03012</b>	<b>RDKF-100-03012</b>	RDCL-011-00076	RDTF-031-00070	RDRY-701-00312	7

注释：每种滚筒抛光工具都装配有锁紧器、锥体和辊。

钻削

B

镗孔

C

铰孔

D

抛光

E

螺纹加工

X

特殊应用

说明请参见：1

D : 42 - 45

D : 40 - 41

D : 38



# 滚筒抛光工具 | 盲孔

F系列 | 直径范围 : 0.9661" - 1.2268" (24.54 mm - 31.16 mm)

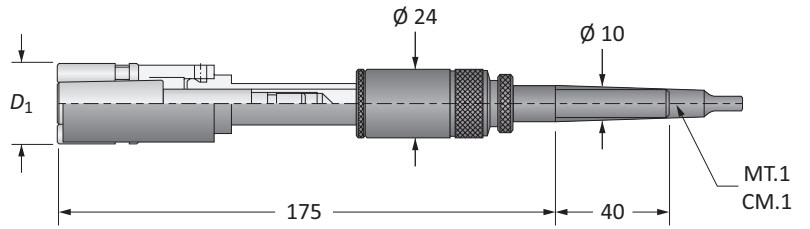

D <sub>1</sub>		零件号*		备件			
英制 (in)	公制 (mm)	包含莫氏锥柄的总成	包含直柄的总成	锁紧器	锥体**	辊	辊数量
0.9661 - 1.0075	24.54 - 25.59	RSKF-200-xxxxx	RSKF-100-xxxxx	RSCL-015-00062	RSTF-03x-00062	RSRY-708-00265	5
0.9992 - 1.0402	25.38 - 26.42	RSKF-200-xxxxx	RSKF-100-xxxxx	RSCL-015-00064	RSTF-03x-00064	RSRY-708-00265	5
1.0299 - 1.0709	26.16 - 27.20	RSKF-200-xxxxx	RSKF-100-xxxxx	RSCL-015-00066	RSTF-03x-00066	RSRY-708-00265	5
1.0610 - 1.1024	26.95 - 28.00	RSKF-200-xxxxx	RSKF-100-xxxxx	RSCL-015-00068	RSTF-03x-00068	RSRY-708-00265	5
1.0917 - 1.1327	27.73 - 28.77	RSKF-200-xxxxx	RSKF-100-xxxxx	RSCL-015-00070	RSTF-03x-00070	RSRY-708-00265	5
1.1240 - 1.1650	28.55 - 29.59	RSKF-200-xxxxx	RSKF-100-xxxxx	RSCL-015-00072	RSTF-03x-00066	RSRY-708-00312	5
1.1551 - 1.1965	29.34 - 30.39	RSKF-200-xxxxx	RSKF-100-xxxxx	RSCL-015-00074	RSTF-03x-00068	RSRY-708-00312	5
1.1858 - 1.2268	30.12 - 31.16	RSKF-200-xxxxx	RSKF-100-xxxxx	RSCL-015-00076	RSTF-03x-00070	RSRY-708-00312	5

\*xxxxx = 指示包含2位小数的公制待抛光尺寸 (例如直径为27.00 mm, 带MT.1柄的滚筒抛光工具: RSKF-200-02700)。  
 \*\*x = 一个在2 - 8的范围内变化的数字, 具体取决于精确的待抛光直径。有关 "x" 值的正确识别, 请参见第D : 6页。  
 注释: 每种滚筒抛光工具都装配有锁紧器、锥体和辊。

D : 42 - 45

D : 40 - 41

D : 39

说明请参见D : 1

A 滚筒抛光工具 | 通孔

M系列 | 直径范围：1.2146" - 1.4118" (30.85 mm - 35.86 mm)

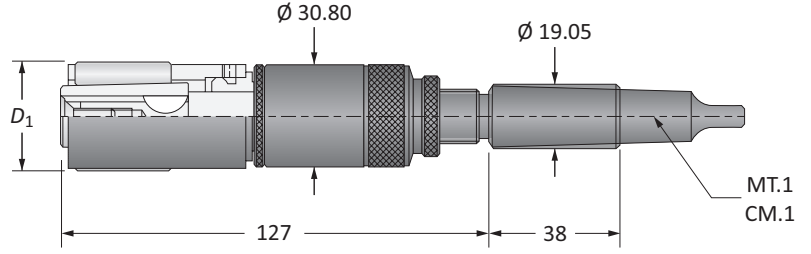

D <sub>1</sub>		零件号		备件			
英制 (in)	公制 (mm)	包含莫氏锥柄的总成	包含直柄的总成	锁紧器	锥体	辊	辊数量
1.2146 - 1.2559	30.85 - 31.90	<b>RDKM-200-03085</b>	<b>RDKM-100-03085</b>	RDCM-011-00078	RDTM-031-00078	RDRY-701-00265	7
1.2469 - 1.2878	31.67 - 32.71	<b>RDKM-200-03167</b>	<b>RDKM-100-03167</b>	RDCM-011-00080	RDTM-031-00080	RDRY-701-00265	7
1.2772 - 1.3177	32.44 - 33.47	<b>RDKM-200-03244</b>	<b>RDKM-100-03244</b>	RDCM-011-00082	RDTM-031-00082	RDRY-701-00265	7
1.3087 - 1.3500	33.24 - 34.29	<b>RDKM-200-03324</b>	<b>RDKM-100-03324</b>	RDCM-011-00084	RDTM-031-00078	RDRY-701-00312	7
1.3406 - 1.3815	34.05 - 35.09	<b>RDKM-200-03405</b>	<b>RDKM-100-03405</b>	RDCM-011-00086	RDTM-031-00080	RDRY-701-00312	7
1.3713 - 1.4118	34.83 - 35.86	<b>RDKM-200-03483</b>	<b>RDKM-100-03483</b>	RDCM-011-00088	RDTM-031-00082	RDRY-701-00312	7

注释：每种滚筒抛光工具都装配有锁紧器、锥体和辊。

C 铰孔

D 抛光

E 螺纹加工

X 特殊应用

D : 42 - 45      D : 40 - 41      D : 38

说明请参见：1



## 滚筒抛光工具 | 盲孔

M系列 | 直径范围：1.2146" - 1.4118" (30.85 mm - 35.86 mm)

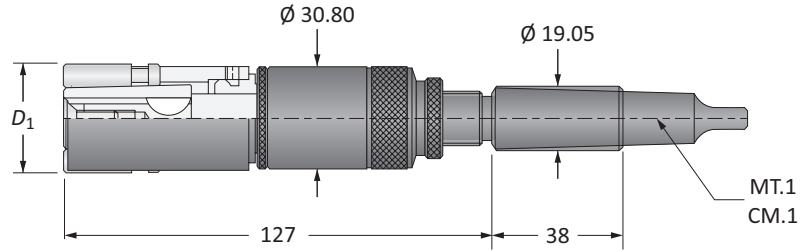

D <sub>1</sub>		零件号*		备件			
英制 (in)	公制 (mm)	包含莫氏锥柄的总成	包含直柄的总成	锁紧器	锥体**	辊	辊数量
1.2146 - 1.2559	30.85 - 31.90	RSKM-200-xxxxxx	RSKM-100-xxxxxx	RSCM-015-00078	RSTM-03x-00078	RSRY-708-00265	5
1.2469 - 1.2878	31.67 - 32.71	RSKM-200-xxxxxx	RSKM-100-xxxxxx	RSCM-015-00080	RSTM-03x-00080	RSRY-708-00265	5
1.2772 - 1.3177	32.44 - 33.47	RSKM-200-xxxxxx	RSKM-100-xxxxxx	RSCM-015-00082	RSTM-03x-00082	RSRY-708-00265	5
1.3087 - 1.3500	33.24 - 34.29	RSKM-200-xxxxxx	RSKM-100-xxxxxx	RSCM-015-00084	RSTM-03x-00078	RSRY-708-00312	5
1.3406 - 1.3815	34.05 - 35.09	RSKM-200-xxxxxx	RSKM-100-xxxxxx	RSCM-015-00086	RSTM-03x-00080	RSRY-708-00312	5
1.3713 - 1.4118	34.83 - 35.86	RSKM-200-xxxxxx	RSKM-100-xxxxxx	RSCM-015-00088	RSTM-03x-00082	RSRY-708-00312	5

\*xxxxx = 指示包含2位小数的公制待抛光尺寸 (例如直径为35.00 mm, 带MT.2柄的滚筒抛光工具: RSKM-200-03500)。

\*\*x = 一个在2 - 8的范围内变化的数字, 具体取决于精确的待抛光直径。有关“x”值的正确识别, 请参见第D: 6页。

注释: 每种滚筒抛光工具都装配有锁紧器、锥体和辊。

D : 42 - 45

D : 40 - 41

D : 39

说明请参见D: 1

## 滚筒抛光工具 | 通孔

N系列 | 直径范围：1.4020" - 1.8492" (35.61 mm - 46.97 mm)

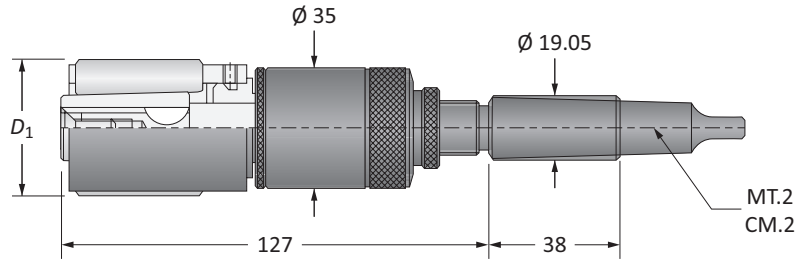

D <sub>1</sub>		零件号		备件			
英制 (in)	公制 (mm)	包含莫氏锥柄的总成	包含直柄的总成	锁紧器	锥体	辊	辊数量
1.4020 - 1.4433	35.61 - 36.66	<b>RDKN-200-03561</b>	<b>RDKN-100-03561</b>	RDCN-011-00090	RDTN-031-00090	RDRY-701-00312	7
1.4331 - 1.4740	36.40 - 37.44	<b>RDKN-200-03640</b>	<b>RDKN-100-03640</b>	RDCN-011-00092	RDTN-031-00092	RDRY-701-00312	7
1.4638 - 1.5051	37.18 - 38.23	<b>RDKN-200-03718</b>	<b>RDKN-100-03718</b>	RDCN-011-00094	RDTN-031-00094	RDRY-701-00312	7
1.4961 - 1.5370	38.00 - 39.04	<b>RDKN-200-03800</b>	<b>RDKN-100-03800</b>	RDCN-011-00096	RDTN-031-00096	RDRY-701-00312	7
1.5272 - 1.5677	38.79 - 39.82	<b>RDKN-200-03879</b>	<b>RDKN-100-03879</b>	RDCN-011-00098	RDTM-031-00080	RDRY-701-00406	7
1.5579 - 1.5992	39.57 - 40.62	<b>RDKN-200-03957</b>	<b>RDKN-100-03957</b>	RDCN-011-00100	RDTM-031-00082	RDRY-701-00406	7
1.5890 - 1.6299	40.36 - 41.40	<b>RDKN-200-04036</b>	<b>RDKN-100-04036</b>	RDCN-011-00102	RDTN-031-00090	RDRY-701-00406	7
1.6213 - 1.6618	41.18 - 42.21	<b>RDKN-200-04118</b>	<b>RDKN-100-04118</b>	RDCN-011-00104	RDTN-031-00092	RDRY-701-00406	7
1.6520 - 1.6933	41.96 - 43.01	<b>RDKN-200-04196</b>	<b>RDKN-100-04196</b>	RDCN-011-00106	RDTN-031-00094	RDRY-701-00406	7
1.6831 - 1.7240	42.75 - 43.79	<b>RDKN-200-04275</b>	<b>RDKN-100-04275</b>	RDCN-011-00108	RDTM-031-00082	RDRY-701-00468	7
1.7138 - 1.7551	43.53 - 44.58	<b>RDKN-200-04353</b>	<b>RDKN-100-04353</b>	RDCN-011-00110	RDTN-031-00090	RDRY-701-00468	7
1.7461 - 1.7870	44.35 - 45.39	<b>RDKN-200-04435</b>	<b>RDKN-100-04435</b>	RDCN-011-00112	RDTN-031-00092	RDRY-701-00468	7
1.7772 - 1.8177	45.14 - 46.17	<b>RDKN-200-04514</b>	<b>RDKN-100-04514</b>	RDCN-011-00114	RDTN-031-00094	RDRY-701-00468	7
1.8079 - 1.8492	45.92 - 46.97	<b>RDKN-200-04592</b>	<b>RDKN-100-04592</b>	RDCN-011-00116	RDTN-031-00096	RDRY-701-00468	7

注释：每种滚筒抛光工具都装配有锁紧器、锥体和辊。

D 抛光

E 螺纹加工

X 特殊应用

说明请参见：1

D : 42 - 45

D : 40 - 41

D : 38





# 滚筒抛光工具 | 盲孔

N系列 | 直径范围：1.4020" - 1.8492" (35.61 mm - 46.97 mm)

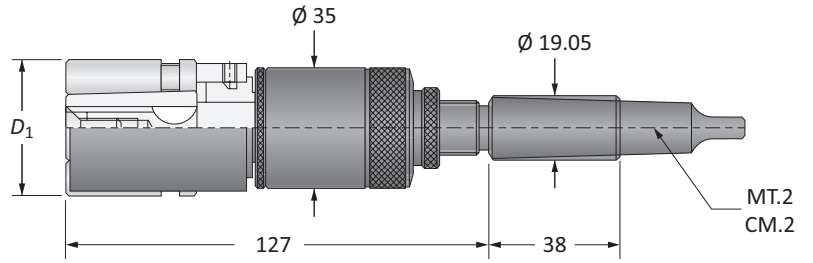

D <sub>1</sub>		零件号*		备件			
英制 (in)	公制 (mm)	包含莫氏锥柄的总成	包含直柄的总成	锁紧器	锥体**	辊	辊数量
1.4020 - 1.4433	35.61 - 36.66	RSKN-200-xxxxx	RSKN-100-xxxxx	RSCN-015-00090	RSTN-03x-00090	RSRY-708-00312	5
1.4331 - 1.4740	36.40 - 37.44	RSKN-200-xxxxx	RSKN-100-xxxxx	RSCN-015-00092	RSTN-03x-00092	RSRY-708-00312	5
1.4638 - 1.5051	37.18 - 38.23	RSKN-200-xxxxx	RSKN-100-xxxxx	RSCN-015-00094	RSTN-03x-00094	RSRY-708-00312	5
1.4961 - 1.5370	38.00 - 39.04	RSKN-200-xxxxx	RSKN-100-xxxxx	RSCN-015-00096	RSTN-03x-00096	RSRY-708-00312	5
1.5272 - 1.5677	38.79 - 39.82	RSKN-200-xxxxx	RSKN-100-xxxxx	RSCN-015-00098	RSTM-03x-00080	RSRY-708-00406	5
1.5579 - 1.5992	39.57 - 40.62	RSKN-200-xxxxx	RSKN-100-xxxxx	RSCN-015-00100	RSTM-03x-00082	RSRY-708-00406	5
1.5890 - 1.6299	40.36 - 41.40	RSKN-200-xxxxx	RSKN-100-xxxxx	RSCN-015-00102	RSTN-03x-00090	RSRY-708-00406	5
1.6213 - 1.6618	41.18 - 42.21	RSKN-200-xxxxx	RSKN-100-xxxxx	RSCN-015-00104	RSTN-03x-00092	RSRY-708-00406	5
1.6520 - 1.6933	41.96 - 43.01	RSKN-200-xxxxx	RSKN-100-xxxxx	RSCN-015-00106	RSTN-03x-00094	RSRY-708-00406	5
1.6831 - 1.7240	42.75 - 43.79	RSKN-200-xxxxx	RSKN-100-xxxxx	RSCN-015-00108	RSTM-03x-00082	RSRY-708-00468	5
1.7138 - 1.7551	43.53 - 44.58	RSKN-200-xxxxx	RSKN-100-xxxxx	RSCN-015-00110	RSTN-03x-00090	RSRY-708-00468	5
1.7461 - 1.7870	44.35 - 45.39	RSKN-200-xxxxx	RSKN-100-xxxxx	RSCN-015-00112	RSTN-03x-00092	RSRY-708-00468	5
1.7772 - 1.8177	45.14 - 46.17	RSKN-200-xxxxx	RSKN-100-xxxxx	RSCN-015-00114	RSTN-03x-00094	RSRY-708-00468	5
1.8079 - 1.8492	45.92 - 46.97	RSKN-200-xxxxx	RSKN-100-xxxxx	RSCN-015-00116	RSTN-03x-00096	RSRY-708-00468	5

\*xxxxx = 指示包含2位小数的公制待抛光尺寸 (例如直径为40.00 mm, 带直柄的滚筒抛光工具: RSKN-100-04000)。

\*\*x = 一个在2 - 8的范围内变化的数字, 具体取决于精确的待抛光直径。有关 "x" 值的正确识别, 请参见第D: 6页。

注释: 每种滚筒抛光工具都装配有锁紧器、锥体和辊。

D : 42 - 45

D : 40 - 41

D : 39

说明请参见D: 1

## 滚筒抛光工具 | 通孔

O系列 | 直径范围：1.8390" - 2.2240" (46.71 mm - 56.49 mm)

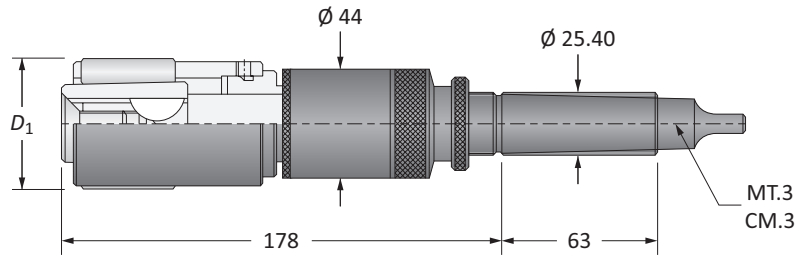

### 通孔

D <sub>1</sub>		零件号		备件			
英制 (in)	公制 (mm)	包含莫氏锥柄的总成	包含直柄的总成	锁紧器	锥体	辊	辊数量
1.8390 - 1.8799	46.71 - 47.75	<b>RDKO-200-04671</b>	<b>RDKO-100-04671</b>	RDCO-011-00118	RDTO-031-00118	RDRY-701-00312	9
1.8713 - 1.9118	47.53 - 48.56	<b>RDKO-200-04753</b>	<b>RDKO-100-04753</b>	RDCO-011-00120	RDTO-031-00120	RDRY-701-00312	9
1.9020 - 1.9433	48.31 - 49.36	<b>RDKO-200-04831</b>	<b>RDKO-100-04831</b>	RDCO-011-00122	RDTO-031-00122	RDRY-701-00312	9
1.9331 - 1.9740	49.10 - 50.14	<b>RDKO-200-04910</b>	<b>RDKO-100-04910</b>	RDCO-011-00124	RDTO-031-00124	RDRY-701-00312	9
1.9638 - 2.0051	49.88 - 50.93	<b>RDKO-200-04988</b>	<b>RDKO-100-04988</b>	RDCO-011-00126	RDTO-031-00126	RDRY-701-00312	9
1.9961 - 2.0370	50.70 - 51.74	<b>RDKO-200-05070</b>	<b>RDKO-100-05070</b>	RDCO-011-00128	RDTO-031-00128	RDRY-701-00312	9
2.0272 - 2.0681	51.49 - 52.53	<b>RDKO-200-05149</b>	<b>RDKO-100-05149</b>	RDCO-011-00130	RDTO-031-00118	RDRY-701-00406	9
2.0579 - 2.0992	52.27 - 53.32	<b>RDKO-200-05227</b>	<b>RDKO-100-05227</b>	RDCO-011-00132	RDTO-031-00120	RDRY-701-00406	9
2.0890 - 2.1299	53.06 - 54.10	<b>RDKO-200-05306</b>	<b>RDKO-100-05306</b>	RDCO-011-00134	RDTO-031-00122	RDRY-701-00406	9
2.1209 - 2.1618	53.87 - 54.91	<b>RDKO-200-05387</b>	<b>RDKO-100-05387</b>	RDCO-011-00136	RDTO-031-00124	RDRY-701-00406	9
2.1520 - 2.1933	54.66 - 55.71	<b>RDKO-200-05466</b>	<b>RDKO-100-05466</b>	RDCO-011-00138	RDTO-031-00126	RDRY-701-00406	9
2.1831 - 2.2240	55.45 - 56.49	<b>RDKO-200-05545</b>	<b>RDKO-100-05545</b>	RDCO-011-00140	RDTO-031-00128	RDRY-701-00406	9

注释：每种滚筒抛光工具都装配有锁紧器、锥体和辊。

D : 42 - 45

D : 40 - 41

D : 38

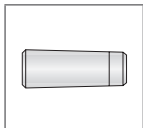
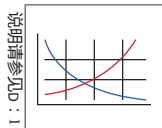

说明请参见 1



## 滚筒抛光工具 | 盲孔

0系列 | 直径范围：1.8390" - 2.2240" (46.71 mm - 56.49 mm)

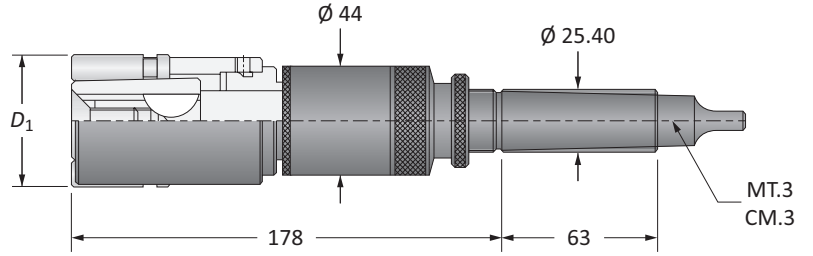

### 盲孔

D <sub>1</sub>		零件号*		备件			
英制 (in)	公制 (mm)	包含莫氏锥柄的总成	包含直柄的总成	锁紧器	锥体**	辊	辊数量
1.8390 - 1.8799	46.71 - 47.75	RSKO-200-xxxxx	RSKO-100-xxxxx	RSCO-015-00118	RSTO-03x-00118	RSRY-708-00312	7
1.8713 - 1.9118	47.53 - 48.56	RSKO-200-xxxxx	RSKO-100-xxxxx	RSCO-015-00120	RSTO-03x-00120	RSRY-708-00312	7
1.9020 - 1.9433	48.31 - 49.36	RSKO-200-xxxxx	RSKO-100-xxxxx	RSCO-015-00122	RSTO-03x-00122	RSRY-708-00312	7
1.9331 - 1.9740	49.10 - 50.14	RSKO-200-xxxxx	RSKO-100-xxxxx	RSCO-015-00124	RSTO-03x-00124	RSRY-708-00312	7
1.9638 - 2.0051	49.88 - 50.93	RSKO-200-xxxxx	RSKO-100-xxxxx	RSCO-015-00126	RSTO-03x-00126	RSRY-708-00312	7
1.9961 - 2.0370	50.70 - 51.74	RSKO-200-xxxxx	RSKO-100-xxxxx	RSCO-015-00128	RSTO-03x-00128	RSRY-708-00312	7
2.0272 - 2.0681	51.49 - 52.53	RSKO-200-xxxxx	RSKO-100-xxxxx	RSCO-015-00130	RSTO-03x-00118	RSRY-708-00406	7
2.0579 - 2.0992	52.27 - 53.32	RSKO-200-xxxxx	RSKO-100-xxxxx	RSCO-015-00132	RSTO-03x-00120	RSRY-708-00406	7
2.0890 - 2.1299	53.06 - 54.10	RSKO-200-xxxxx	RSKO-100-xxxxx	RSCO-015-00134	RSTO-03x-00122	RSRY-708-00406	7
2.1209 - 2.1618	53.87 - 54.91	RSKO-200-xxxxx	RSKO-100-xxxxx	RSCO-015-00136	RSTO-03x-00124	RSRY-708-00406	7
2.1520 - 2.1933	54.66 - 55.71	RSKO-200-xxxxx	RSKO-100-xxxxx	RSCO-015-00138	RSTO-03x-00126	RSRY-708-00406	7
2.1831 - 2.2240	55.45 - 56.49	RSKO-200-xxxxx	RSKO-100-xxxxx	RSCO-015-00140	RSTO-03x-00128	RSRY-708-00406	7

\*xxxxx = 指示包含2位小数的公制待抛光尺寸 (例如直径为50.25 mm, 带MT.3柄的滚筒抛光工具: RSKO-200-05025)。

\*\*x = 一个在2 - 8的范围内变化的数字, 具体取决于精确的待抛光直径。有关“x”值的正确识别, 请参见第D: 6页。

注释: 每种滚筒抛光工具都装配有锁紧器、锥体和辊。

D : 42 - 45

D : 40 - 41

D : 39

说明请参见D: 1

## 滚筒抛光工具 | 通孔

P系列 | 直径范围：2.2138" - 2.7240" (56.23 mm - 69.19 mm)

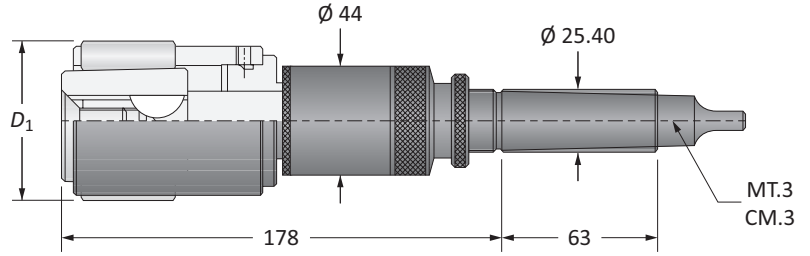

### 通孔

D <sub>1</sub>		零件号		备件			
英制 (in)	公制 (mm)	包含莫氏锥柄的总成	包含直柄的总成	锁紧器	锥体	辊	辊数量
2.2138 - 2.2551	56.23 - 57.28	<b>RDKP-200-05623</b>	<b>RDKP-100-05623</b>	RDCP-011-00142	RDTP-031-00142	RDRY-701-00406	9
2.2461 - 2.2870	57.05 - 58.09	<b>RDKP-200-05705</b>	<b>RDKP-100-05705</b>	RDCP-011-00144	RDTP-031-00144	RDRY-701-00406	9
2.2772 - 2.3177	57.84 - 58.87	<b>RDKP-200-05784</b>	<b>RDKP-100-05784</b>	RDCP-011-00146	RDTP-031-00146	RDRY-701-00406	9
2.3079 - 2.3492	58.62 - 59.67	<b>RDKP-200-05862</b>	<b>RDKP-100-05862</b>	RDCP-011-00148	RDTP-031-00148	RDRY-701-00406	9
2.3390 - 2.3799	59.41 - 60.45	<b>RDKP-200-05941</b>	<b>RDKP-100-05941</b>	RDCP-011-00150	RDTP-031-00142	RDRY-701-00468	9
2.3713 - 2.4118	60.23 - 61.26	<b>RDKP-200-06023</b>	<b>RDKP-100-06023</b>	RDCP-011-00152	RDTP-031-00144	RDRY-701-00468	9
2.4020 - 2.4433	61.01 - 62.06	<b>RDKP-200-06101</b>	<b>RDKP-100-06101</b>	RDCP-011-00154	RDTP-031-00146	RDRY-701-00468	9
2.4330 - 2.4740	61.80 - 62.84	<b>RDKP-200-06180</b>	<b>RDKP-100-06180</b>	RDCP-011-00156	RDTP-031-00148	RDRY-701-00468	9
2.4638 - 2.5051	62.58 - 63.63	<b>RDKP-200-06258</b>	<b>RDKP-100-06258</b>	RDCP-011-00158	RDTP-031-00158	RDRY-701-00468	9
2.4961 - 2.5370	63.40 - 64.44	<b>RDKP-200-06340</b>	<b>RDKP-100-06340</b>	RDCP-011-00160	RDTP-031-00160	RDRY-701-00468	9
2.5272 - 2.5677	64.19 - 65.22	<b>RDKP-200-06419</b>	<b>RDKP-100-06419</b>	RDCP-011-00162	RDTP-031-00162	RDRY-701-00468	9
2.5579 - 2.5992	64.97 - 66.02	<b>RDKP-200-06497</b>	<b>RDKP-100-06497</b>	RDCP-011-00164	RDTP-031-00164	RDRY-701-00468	9
2.5890 - 2.6299	65.76 - 66.80	<b>RDKP-200-06576</b>	<b>RDKP-100-06576</b>	RDCP-011-00166	RDTP-031-00158	RDRY-701-00531	9
2.6213 - 2.6618	66.58 - 67.61	<b>RDKP-200-06658</b>	<b>RDKP-100-06658</b>	RDCP-011-00168	RDTP-031-00160	RDRY-701-00531	9
2.6520 - 2.6933	67.36 - 68.41	<b>RDKP-200-06736</b>	<b>RDKP-100-06736</b>	RDCP-011-00170	RDTP-031-00162	RDRY-701-00531	9
2.6830 - 2.7240	68.15 - 69.19	<b>RDKP-200-06815</b>	<b>RDKP-100-06815</b>	RDCP-011-00172	RDTP-031-00164	RDRY-701-00531	9

注释：每种滚筒抛光工具都装配有锁紧器、锥体和辊。

D : 42 - 45

D : 40 - 41

D : 38

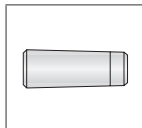
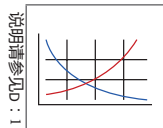

说明请参见 1 : 1



## 滚筒抛光工具 | 盲孔

P系列 | 直径范围：2.2138" - 2.7240" (56.23 mm - 69.19 mm)

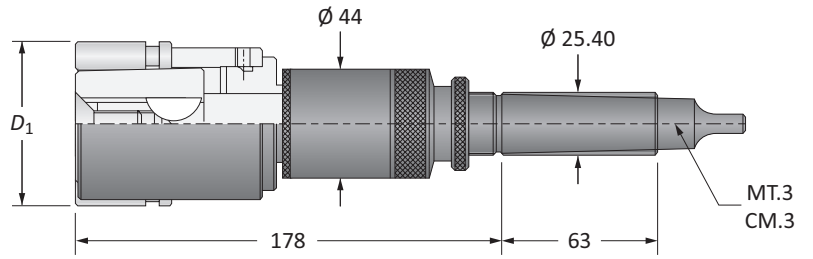

### 盲孔

D <sub>1</sub>		零件号*		备件			
英制 (in)	公制 (mm)	包含莫氏锥柄的总成	包含直柄的总成	锁紧器	锥体**	辊	辊数量
2.2138 - 2.2551	56.23 - 57.28	RSKP-200-xxxxx	RSKP-100-xxxxx	RSCP-015-00142	RSTP-03x-00142	RSRY-708-00406	7
2.2461 - 2.2870	57.05 - 58.09	RSKP-200-xxxxx	RSKP-100-xxxxx	RSCP-015-00144	RSTP-03x-00144	RSRY-708-00406	7
2.2772 - 2.3177	57.84 - 58.87	RSKP-200-xxxxx	RSKP-100-xxxxx	RSCP-015-00146	RSTP-03x-00146	RSRY-708-00406	7
2.3079 - 2.3492	58.62 - 59.67	RSKP-200-xxxxx	RSKP-100-xxxxx	RSCP-015-00148	RSTP-03x-00148	RSRY-708-00406	7
2.3390 - 2.3799	59.41 - 60.45	RSKP-200-xxxxx	RSKP-100-xxxxx	RSCP-015-00150	RSTP-03x-00142	RSRY-708-00468	7
2.3713 - 2.4118	60.23 - 61.26	RSKP-200-xxxxx	RSKP-100-xxxxx	RSCP-015-00152	RSTP-03x-00144	RSRY-708-00468	7
2.4020 - 2.4433	61.01 - 62.06	RSKP-200-xxxxx	RSKP-100-xxxxx	RSCP-015-00154	RSTP-03x-00146	RSRY-708-00468	7
2.4330 - 2.4740	61.80 - 62.84	RSKP-200-xxxxx	RSKP-100-xxxxx	RSCP-015-00156	RSTP-03x-00148	RSRY-708-00468	7
2.4638 - 2.5051	62.58 - 63.63	RSKP-200-xxxxx	RSKP-100-xxxxx	RSCP-015-00158	RSTP-03x-00158	RSRY-708-00468	7
2.4961 - 2.5370	63.40 - 64.44	RSKP-200-xxxxx	RSKP-100-xxxxx	RSCP-015-00160	RSTP-03x-00160	RSRY-708-00468	7
2.5272 - 2.5677	64.19 - 65.22	RSKP-200-xxxxx	RSKP-100-xxxxx	RSCP-015-00162	RSTP-03x-00162	RSRY-708-00468	7
2.5579 - 2.5992	64.97 - 66.02	RSKP-200-xxxxx	RSKP-100-xxxxx	RSCP-015-00164	RSTP-03x-00164	RSRY-708-00468	7
2.5890 - 2.6299	65.76 - 66.80	RSKP-200-xxxxx	RSKP-100-xxxxx	RSCP-015-00166	RSTP-03x-00158	RSRY-708-00531	7
2.6213 - 2.6618	66.58 - 67.61	RSKP-200-xxxxx	RSKP-100-xxxxx	RSCP-015-00168	RSTP-03x-00160	RSRY-708-00531	7
2.6520 - 2.6933	67.36 - 68.41	RSKP-200-xxxxx	RSKP-100-xxxxx	RSCP-015-00170	RSTP-03x-00162	RSRY-708-00531	7
2.6830 - 2.7240	68.15 - 69.19	RSKP-200-xxxxx	RSKP-100-xxxxx	RSCP-015-00172	RSTP-03x-00164	RSRY-708-00531	7

\*xxxxx = 指示包含2位小数的公制待抛光尺寸 (例如直径为60.05 mm, 带直柄的滚筒抛光工具: RSKP-100-06005)。

\*\*x = 一个在2 - 8的范围内变化的数字, 具体取决于精确的待抛光直径。有关“x”值的正确识别, 请参见第D: 6页。

注释: 每种滚筒抛光工具都装配有锁紧器、锥体和辊。

D : 42 - 45

D : 40 - 41

D : 39

说明请参见D: 1

## 滚筒抛光工具 | 通孔

Q系列 | 直径范围：2.7138" - 3.3492" (68.93 mm - 85.07 mm)

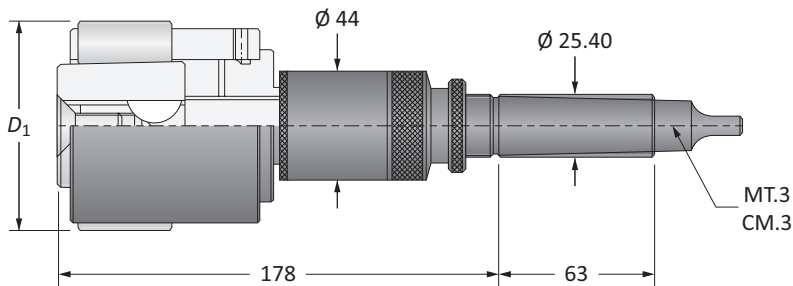

通孔

$D_1$		零件号		备件			
英制 (in)	公制 (mm)	包含莫氏锥柄的总成	包含直柄的总成	锁紧器	锥体	辊	辊数量
2.7138 - 2.7551	68.93 - 69.98	<b>RDKQ-200-06893</b>	<b>RDKQ-100-06893</b>	RDCQ-011-00174	RDTQ-031-00174	RDRY-701-00531	9
2.7461 - 2.7870	69.75 - 70.79	<b>RDKQ-200-06975</b>	<b>RDKQ-100-06975</b>	RDCQ-011-00176	RDTQ-031-00176	RDRY-701-00531	9
2.7772 - 2.8177	70.54 - 71.57	<b>RDKQ-200-07054</b>	<b>RDKQ-100-07054</b>	RDCQ-011-00178	RDTQ-031-00178	RDRY-701-00531	9
2.8079 - 2.8504	71.32 - 72.40	<b>RDKQ-200-07132</b>	<b>RDKQ-100-07132</b>	RDCQ-011-00180	RDTQ-031-00180	RDRY-701-00531	9
2.8390 - 2.8799	72.11 - 73.15	<b>RDKQ-200-07211</b>	<b>RDKQ-100-07211</b>	RDCQ-011-00182	RDTQ-031-00182	RDRY-701-00531	9
2.8713 - 2.9118	72.93 - 73.96	<b>RDKQ-200-07293</b>	<b>RDKQ-100-07293</b>	RDCQ-011-00184	RDTQ-031-00184	RDRY-701-00531	9
2.9020 - 2.9429	73.71 - 74.75	<b>RDKQ-200-07371</b>	<b>RDKQ-100-07371</b>	RDCQ-011-00186	RDTQ-031-00174	RDRY-701-00625	9
2.9331 - 2.9740	74.50 - 75.54	<b>RDKQ-200-07450</b>	<b>RDKQ-100-07450</b>	RDCQ-011-00188	RDTQ-031-00176	RDRY-701-00625	9
2.9638 - 3.0051	75.28 - 76.33	<b>RDKQ-200-07528</b>	<b>RDKQ-100-07528</b>	RDCQ-011-00190	RDTQ-031-00178	RDRY-701-00625	9
2.9961 - 3.0370	76.10 - 77.14	<b>RDKQ-200-07610</b>	<b>RDKQ-100-07610</b>	RDCQ-011-00192	RDTQ-031-00180	RDRY-701-00625	9
3.0272 - 3.0681	76.89 - 77.93	<b>RDKQ-200-07689</b>	<b>RDKQ-100-07689</b>	RDCQ-011-00194	RDTQ-031-00182	RDRY-701-00625	9
3.0579 - 3.0992	77.67 - 78.72	<b>RDKQ-200-07767</b>	<b>RDKQ-100-07767</b>	RDCQ-011-00196	RDTQ-031-00184	RDRY-701-00625	9
3.0890 - 3.1299	78.46 - 79.50	<b>RDKQ-200-07846</b>	<b>RDKQ-100-07846</b>	RDCQ-011-00198	RDTQ-031-00198	RDRY-701-00625	9
3.1209 - 3.1618	79.27 - 80.31	<b>RDKQ-200-07927</b>	<b>RDKQ-100-07927</b>	RDCQ-011-00200	RDTQ-031-00200	RDRY-701-00625	9
3.1520 - 3.1933	80.06 - 81.11	<b>RDKQ-200-08006</b>	<b>RDKQ-100-08006</b>	RDCQ-011-00202	RDTQ-031-00202	RDRY-701-00625	9
3.1831 - 3.2240	80.85 - 81.89	<b>RDKQ-200-08085</b>	<b>RDKQ-100-08085</b>	RDCQ-011-00204	RDTQ-031-00204	RDRY-701-00625	9
3.2138 - 3.2551	81.63 - 82.68	<b>RDKQ-200-08163</b>	<b>RDKQ-100-08163</b>	RDCQ-011-00206	RDTQ-031-00198	RDRY-701-00687	9
3.2461 - 3.2870	82.45 - 83.49	<b>RDKQ-200-08245</b>	<b>RDKQ-100-08245</b>	RDCQ-011-00208	RDTQ-031-00200	RDRY-701-00687	9
3.2772 - 3.3177	83.24 - 84.27	<b>RDKQ-200-08324</b>	<b>RDKQ-100-08324</b>	RDCQ-011-00210	RDTQ-031-00202	RDRY-701-00687	9
3.3079 - 3.3492	84.02 - 85.07	<b>RDKQ-200-08402</b>	<b>RDKQ-100-08402</b>	RDCQ-011-00212	RDTQ-031-00204	RDRY-701-00687	9

注释：每种滚筒抛光工具都装配有锁紧器、锥体和辊。

说明请参见 1 :

D : 42 - 45

D : 40 - 41

D : 38



# 滚筒抛光工具 | 盲孔

Q系列 | 直径范围：2.7138" - 3.3492" (68.93 mm - 85.07 mm)

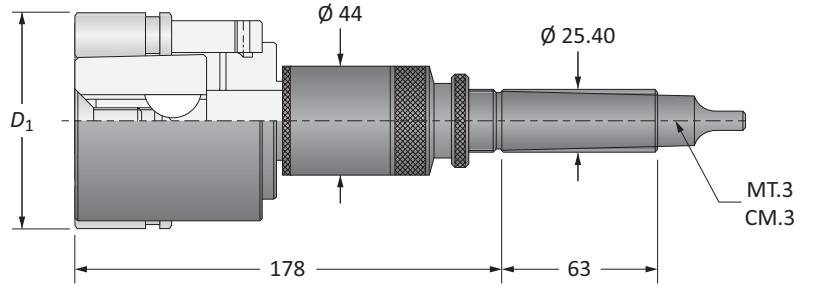

盲孔

D <sub>1</sub>		零件号*		备件			
英制 (in)	公制 (mm)	包含莫氏锥柄的总成	包含直柄的总成	锁紧器	锥体**	辊	辊数量
2.7138 - 2.7551	68.93 - 69.98	RSKQ-200-xxxxx	RSKQ-100-xxxxx	RSCQ-015-00174	RSTQ-03x-00174	RSRY-708-00531	7
2.7461 - 2.7870	69.75 - 70.79	RSKQ-200-xxxxx	RSKQ-100-xxxxx	RSCQ-015-00176	RSTQ-03x-00176	RSRY-708-00531	7
2.7772 - 2.8177	70.54 - 71.57	RSKQ-200-xxxxx	RSKQ-100-xxxxx	RSCQ-015-00178	RSTQ-03x-00178	RSRY-708-00531	7
2.8079 - 2.8504	71.32 - 72.40	RSKQ-200-xxxxx	RSKQ-100-xxxxx	RSCQ-015-00180	RSTQ-03x-00180	RSRY-708-00531	7
2.8390 - 2.8799	72.11 - 73.15	RSKQ-200-xxxxx	RSKQ-100-xxxxx	RSCQ-015-00182	RSTQ-03x-00182	RSRY-708-00531	7
2.8713 - 2.9118	72.93 - 73.96	RSKQ-200-xxxxx	RSKQ-100-xxxxx	RSCQ-015-00184	RSTQ-03x-00184	RSRY-708-00531	7
2.9020 - 2.9429	73.71 - 74.75	RSKQ-200-xxxxx	RSKQ-100-xxxxx	RSCQ-015-00186	RSTQ-03x-00174	RSRY-708-00625	7
2.9331 - 2.9740	74.50 - 75.54	RSKQ-200-xxxxx	RSKQ-100-xxxxx	RSCQ-015-00188	RSTQ-03x-00176	RSRY-708-00625	7
2.9638 - 3.0051	75.28 - 76.33	RSKQ-200-xxxxx	RSKQ-100-xxxxx	RSCQ-015-00190	RSTQ-03x-00178	RSRY-708-00625	7
2.9961 - 3.0370	76.10 - 77.14	RSKQ-200-xxxxx	RSKQ-100-xxxxx	RSCQ-015-00192	RSTQ-03x-00180	RSRY-708-00625	7
3.0272 - 3.0681	76.89 - 77.93	RSKQ-200-xxxxx	RSKQ-100-xxxxx	RSCQ-015-00194	RSTQ-03x-00182	RSRY-708-00625	7
3.0579 - 3.0992	77.67 - 78.72	RSKQ-200-xxxxx	RSKQ-100-xxxxx	RSCQ-015-00196	RSTQ-03x-00184	RSRY-708-00625	7
3.0890 - 3.1299	78.46 - 79.50	RSKQ-200-xxxxx	RSKQ-100-xxxxx	RSCQ-015-00198	RSTQ-03x-00198	RSRY-708-00625	7
3.1209 - 3.1618	79.27 - 80.31	RSKQ-200-xxxxx	RSKQ-100-xxxxx	RSCQ-015-00200	RSTQ-03x-00200	RSRY-708-00625	7
3.1520 - 3.1933	80.06 - 81.11	RSKQ-200-xxxxx	RSKQ-100-xxxxx	RSCQ-015-00202	RSTQ-03x-00202	RSRY-708-00625	7
3.1831 - 3.2240	80.85 - 81.89	RSKQ-200-xxxxx	RSKQ-100-xxxxx	RSCQ-015-00204	RSTQ-03x-00204	RSRY-708-00625	7
3.2138 - 3.2551	81.63 - 82.68	RSKQ-200-xxxxx	RSKQ-100-xxxxx	RSCQ-015-00206	RSTQ-03x-00198	RSRY-708-00687	7
3.2461 - 3.2870	82.45 - 83.49	RSKQ-200-xxxxx	RSKQ-100-xxxxx	RSCQ-015-00208	RSTQ-03x-00200	RSRY-708-00687	7
3.2772 - 3.3177	83.24 - 84.27	RSKQ-200-xxxxx	RSKQ-100-xxxxx	RSCQ-015-00210	RSTQ-03x-00202	RSRY-708-00687	7
3.3079 - 3.3492	84.02 - 85.07	RSKQ-200-xxxxx	RSKQ-100-xxxxx	RSCQ-015-00212	RSTQ-03x-00204	RSRY-708-00687	7

\*xxxxx = 指示包含2位小数的公制待抛光尺寸 (例如直径为75.00 mm, 带MT.3柄的滚筒抛光工具: RSKQ-200-07500)。  
 \*\*x = 一个在2-8的范围内变化的数字, 具体取决于精确的待抛光直径。有关 "x" 值的正确识别, 请参见第D: 6页。  
 注释: 每种滚筒抛光工具都装配有锁紧器、锥体和辊。

D : 42 - 45      D : 40 - 41      D : 39

说明请参见D: 1

Q  
A  
钻削  
B  
镗孔  
C  
铰孔  
D  
抛光  
E  
螺纹加工  
X  
特殊应用

A 滚筒抛光工具 | 通孔

R系列 | 直径范围：3.3390" - 4.0992" (84.81 mm - 104.12 mm)

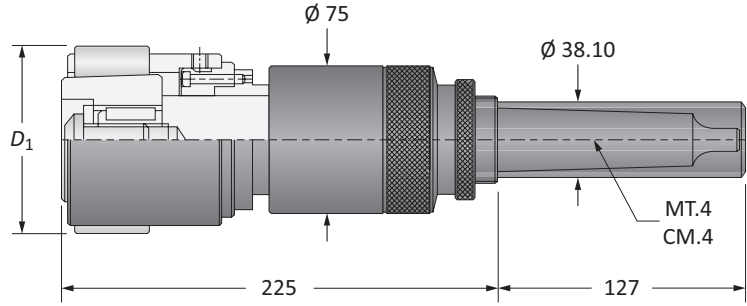

B 通孔

D <sub>1</sub>		零件号		备件			
英制 (in)	公制 (mm)	包含莫氏锥柄的总成	包含直柄的总成	锁紧器	锥体	辊	辊数量
3.3390 - 3.3799	84.81 - 85.85	RDKR-200-08481	RDKR-100-08481	RDCR-011-00214	RDTR-073-00001	RDRY-701-00468	9
3.3713 - 3.4118	85.63 - 86.66	RDKR-200-08563	RDKR-100-08563	RDCR-011-00216	RDTR-074-00001	RDRY-701-00468	9
3.4020 - 3.4429	86.41 - 87.45	RDKR-200-08641	RDKR-100-08641	RDCR-011-00218	RDTR-071-00001	RDRY-701-00531	9
3.4331 - 3.4740	87.20 - 88.24	RDKR-200-08720	RDKR-100-08720	RDCR-011-00220	RDTR-072-00001	RDRY-701-00531	9
3.4642 - 3.5051	87.99 - 89.03	RDKR-200-08799	RDKR-100-08799	RDCR-011-00222	RDTR-073-00001	RDRY-701-00531	9
3.4957 - 3.5370	88.79 - 89.84	RDKR-200-08879	RDKR-100-08879	RDCR-011-00224	RDTR-074-00001	RDRY-701-00531	9
3.5272 - 3.5681	89.59 - 90.63	RDKR-200-08959	RDKR-100-08959	RDCR-011-00226	RDTR-075-00001	RDRY-701-00531	9
3.5579 - 3.5992	90.37 - 91.42	RDKR-200-09037	RDKR-100-09037	RDCR-011-00228	RDTR-076-00001	RDRY-701-00531	9
3.5890 - 3.6299	91.16 - 92.20	RDKR-200-09116	RDKR-100-09116	RDCR-011-00230	RDTR-071-00001	RDRY-701-00625	9
3.6209 - 3.6622	91.97 - 93.02	RDKR-200-09197	RDKR-100-09197	RDCR-011-00232	RDTR-072-00001	RDRY-701-00625	9
3.6520 - 3.6929	92.76 - 93.80	RDKR-200-09276	RDKR-100-09276	RDCR-011-00234	RDTR-073-00001	RDRY-701-00625	9
3.6831 - 3.7240	93.55 - 94.59	RDKR-200-09355	RDKR-100-09355	RDCR-011-00236	RDTR-074-00001	RDRY-701-00625	9
3.7142 - 3.7551	94.34 - 95.38	RDKR-200-09434	RDKR-100-09434	RDCR-011-00238	RDTR-075-00001	RDRY-701-00625	9
3.7461 - 3.7870	95.15 - 96.19	RDKR-200-09515	RDKR-100-09515	RDCR-011-00240	RDTR-076-00001	RDRY-701-00625	9
3.7772 - 3.8181	95.94 - 96.98	RDKR-200-09594	RDKR-100-09594	RDCR-011-00242	RDTR-077-00001	RDRY-701-00625	9
3.8079 - 3.8492	96.72 - 97.77	RDKR-200-09672	RDKR-100-09672	RDCR-011-00244	RDTR-078-00001	RDRY-701-00625	9
3.8390 - 3.8799	97.51 - 98.55	RDKR-200-09751	RDKR-100-09751	RDCR-011-00246	RDTR-075-00001	RDRY-701-00687	9
3.8709 - 3.9122	98.32 - 99.37	RDKR-200-09832	RDKR-100-09832	RDCR-011-00248	RDTR-076-00001	RDRY-701-00687	9
3.9020 - 3.9429	99.11 - 100.15	RDKR-200-09911	RDKR-100-09911	RDCR-011-00250	RDTR-077-00001	RDRY-701-00687	9
3.9331 - 3.9740	99.90 - 100.94	RDKR-200-09990	RDKR-100-09990	RDCR-011-00252	RDTR-078-00001	RDRY-701-00687	9
3.9642 - 4.0051	100.69 - 101.73	RDKR-200-10069	RDKR-100-10069	RDCR-011-00254	RDTR-079-00001	RDRY-701-00687	9
3.9961 - 4.0370	101.50 - 102.54	RDKR-200-10150	RDKR-100-10150	RDCR-011-00256	RDTR-080-00001	RDRY-701-00687	9
4.0272 - 1.0681	102.29 - 103.33	RDKR-200-10229	RDKR-100-10229	RDCR-011-00258	RDTR-081-00001	RDRY-701-00687	9
4.0579 - 4.0992	103.07 - 104.12	RDKR-200-10307	RDKR-100-10307	RDCR-011-00260	RDTR-082-00001	RDRY-701-00687	9

注释：每种滚筒抛光工具都装配有锁紧器、锥体和辊。

C 镗孔

D 铰孔

E 抛光

F 螺纹加工

X 特殊应用

D : 42 - 45      D : 40 - 41      D : 38

说明请参见 1 : 1





# 滚筒抛光工具 | 盲孔

R系列 | 直径范围 : 3.3390" - 4.0992" (84.81 mm - 104.12 mm)

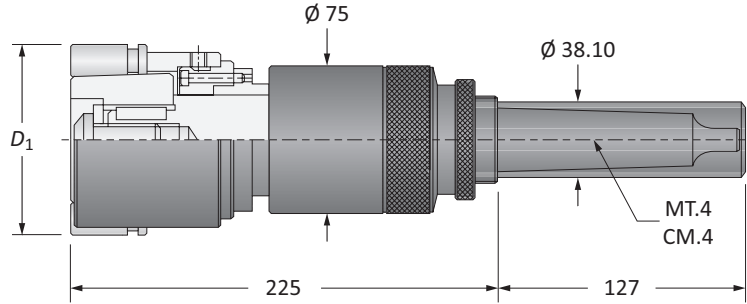

盲孔

D <sub>1</sub>		零件号*		备件			
英制 (in)	公制 (mm)	包含莫氏锥柄的总成	包含直柄的总成	锁紧器	锥体**	辊	辊数量
3.3390 - 3.3799	84.81 - 85.85	RSKR-200-xxxxx	RSKR-100-xxxxx	RSCR-015-00214	RSTR-073-0000x	RSRY-708-00468	9
3.3713 - 3.4118	85.63 - 86.66	RSKR-200-xxxxx	RSKR-100-xxxxx	RSCR-015-00216	RSTR-074-0000x	RSRY-708-00468	9
3.4020 - 3.4429	86.41 - 87.45	RSKR-200-xxxxx	RSKR-100-xxxxx	RSCR-015-00218	RSTR-071-0000x	RSRY-708-00531	9
3.4331 - 3.4740	87.20 - 88.24	RSKR-200-xxxxx	RSKR-100-xxxxx	RSCR-015-00220	RSTR-072-0000x	RSRY-708-00531	9
3.4642 - 3.5051	87.99 - 89.03	RSKR-200-xxxxx	RSKR-100-xxxxx	RSCR-015-00222	RSTR-073-0000x	RSRY-708-00531	9
3.4957 - 3.5370	88.79 - 89.84	RSKR-200-xxxxx	RSKR-100-xxxxx	RSCR-015-00224	RSTR-074-0000x	RSRY-708-00531	9
3.5272 - 3.5681	89.59 - 90.63	RSKR-200-xxxxx	RSKR-100-xxxxx	RSCR-015-00226	RSTR-075-0000x	RSRY-708-00531	9
3.5579 - 3.5992	90.37 - 91.42	RSKR-200-xxxxx	RSKR-100-xxxxx	RSCR-015-00228	RSTR-076-0000x	RSRY-708-00531	9
3.5890 - 3.6299	91.16 - 92.20	RSKR-200-xxxxx	RSKR-100-xxxxx	RSCR-015-00230	RSTR-071-0000x	RSRY-708-00625	9
3.6209 - 3.6622	91.97 - 93.02	RSKR-200-xxxxx	RSKR-100-xxxxx	RSCR-015-00232	RSTR-072-0000x	RSRY-708-00625	9
3.6520 - 3.6929	92.76 - 93.80	RSKR-200-xxxxx	RSKR-100-xxxxx	RSCR-015-00234	RSTR-073-0000x	RSRY-708-00625	9
3.6831 - 3.7240	93.55 - 94.59	RSKR-200-xxxxx	RSKR-100-xxxxx	RSCR-015-00236	RSTR-074-0000x	RSRY-708-00625	9
3.7142 - 3.7551	94.34 - 95.38	RSKR-200-xxxxx	RSKR-100-xxxxx	RSCR-015-00238	RSTR-075-0000x	RSRY-708-00625	9
3.7461 - 3.7870	95.15 - 96.19	RSKR-200-xxxxx	RSKR-100-xxxxx	RSCR-015-00240	RSTR-076-0000x	RSRY-708-00625	9
3.7772 - 3.8181	95.94 - 96.98	RSKR-200-xxxxx	RSKR-100-xxxxx	RSCR-015-00242	RSTR-077-0000x	RSRY-708-00625	9
3.8079 - 3.8492	96.72 - 97.77	RSKR-200-xxxxx	RSKR-100-xxxxx	RSCR-015-00244	RSTR-078-0000x	RSRY-708-00625	9
3.8390 - 3.8799	97.51 - 98.55	RSKR-200-xxxxx	RSKR-100-xxxxx	RSCR-015-00246	RSTR-075-0000x	RSRY-708-00687	9
3.8709 - 3.9122	98.32 - 99.37	RSKR-200-xxxxx	RSKR-100-xxxxx	RSCR-015-00248	RSTR-076-0000x	RSRY-708-00687	9
3.9020 - 3.9429	99.11 - 100.15	RSKR-200-xxxxx	RSKR-100-xxxxx	RSCR-015-00250	RSTR-077-0000x	RSRY-708-00687	9
3.9331 - 3.9740	99.90 - 100.94	RSKR-200-xxxxx	RSKR-100-xxxxx	RSCR-015-00252	RSTR-078-0000x	RSRY-708-00687	9
3.9642 - 4.0051	100.69 - 101.73	RSKR-200-xxxxx	RSKR-100-xxxxx	RSCR-015-00254	RSTR-079-0000x	RSRY-708-00687	9
3.9961 - 4.0370	101.50 - 102.54	RSKR-200-xxxxx	RSKR-100-xxxxx	RSCR-015-00256	RSTR-080-0000x	RSRY-708-00687	9
4.0272 - 1.0681	102.29 - 103.33	RSKR-200-xxxxx	RSKR-100-xxxxx	RSCR-015-00258	RSTR-081-0000x	RSRY-708-00687	9
4.0579 - 4.0992	103.07 - 104.12	RSKR-200-xxxxx	RSKR-100-xxxxx	RSCR-015-00260	RSTR-082-0000x	RSRY-708-00687	9

\*xxxxx = 指示包含2位小数的公制待抛光尺寸 (例如直径为100.00 mm, 带直柄的滚筒抛光工具: RSKR-100-10000)。

\*\*x = 一个在2 - 8的范围内变化的数字, 具体取决于精确的待抛光直径。有关 "x" 值的正确识别, 请参见第D : 6页。

注释: 每种滚筒抛光工具都装配有锁紧器、锥体和辊。

D : 42 - 45

D : 40 - 41

D : 39

说明请参见D : 1

A 滚筒抛光工具 | 通孔

s系列 | 直径范围：4.0890" - 5.0370" (103.86 mm - 127.94 mm)

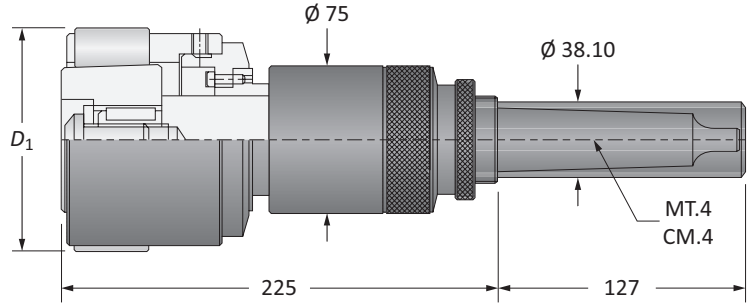

B 通孔

D <sub>1</sub>		零件号		备件			
英制 (in)	公制 (mm)	包含莫氏锥柄的总成	包含直柄的总成	锁紧器	锥体	辊	辊数量
4.0890 - 4.1299	103.86 - 104.90	RDKS-200-10386	RDKS-100-10386	RDCS-011-00262	RDTS-083-00001	RDRY-701-00687	9
4.1209 - 4.1634	104.67 - 105.75	RDKS-200-10467	RDKS-100-10467	RDCS-011-00264	RDTS-084-00001	RDRY-701-00687	9
4.1520 - 4.1929	105.46 - 106.50	RDKS-200-10546	RDKS-100-10546	RDCS-011-00266	RDTS-085-00001	RDRY-701-00687	9
4.1831 - 4.2240	106.25 - 107.29	RDKS-200-10625	RDKS-100-10625	RDCS-011-00268	RDTS-086-00001	RDRY-701-00687	9
4.2142 - 4.2551	107.04 - 108.08	RDKS-200-10704	RDKS-100-10704	RDCS-011-00270	RDTS-087-00001	RDRY-701-00687	9
4.2461 - 4.2870	107.85 - 108.89	RDKS-200-10785	RDKS-100-10785	RDCS-011-00272	RDTS-088-00001	RDRY-701-00687	9
4.2772 - 4.3181	108.64 - 109.68	RDKS-200-10864	RDKS-100-10864	RDCS-011-00274	RDTS-089-00001	RDRY-701-00687	9
4.3079 - 4.3492	109.42 - 110.47	RDKS-200-10942	RDKS-100-10942	RDCS-011-00276	RDTS-090-00001	RDRY-701-00687	9
4.3390 - 4.3799	110.21 - 111.25	RDKS-200-11021	RDKS-100-11021	RDCS-011-00278	RDTS-083-00001	RDRY-701-00812	9
4.3709 - 4.4122	111.02 - 112.07	RDKS-200-11102	RDKS-100-11102	RDCS-011-00280	RDTS-084-00001	RDRY-701-00812	9
4.4020 - 4.4429	111.81 - 112.85	RDKS-200-11181	RDKS-100-11181	RDCS-011-00282	RDTS-085-00001	RDRY-701-00812	9
4.4331 - 4.4740	112.60 - 113.64	RDKS-200-11260	RDKS-100-11260	RDCS-011-00284	RDTS-086-00001	RDRY-701-00812	9
4.4622 - 4.5051	113.34 - 114.43	RDKS-200-11334	RDKS-100-11334	RDCS-011-00286	RDTS-087-00001	RDRY-701-00812	9
4.4961 - 4.5370	114.20 - 115.24	RDKS-200-11420	RDKS-100-11420	RDCS-011-00288	RDTS-088-00001	RDRY-701-00812	9
4.5272 - 4.5681	114.99 - 116.03	RDKS-200-11499	RDKS-100-11499	RDCS-011-00290	RDTS-089-00001	RDRY-701-00812	9
4.5579 - 4.5992	115.77 - 116.82	RDKS-200-11577	RDKS-100-11577	RDCS-011-00292	RDTS-090-00001	RDRY-701-00812	9
4.5890 - 4.6299	116.56 - 117.60	RDKS-200-11656	RDKS-100-11656	RDCS-011-00294	RDTS-091-00001	RDRY-701-00812	9
4.6209 - 4.6622	117.37 - 118.42	RDKS-200-11737	RDKS-100-11737	RDCS-011-00296	RDTS-092-00001	RDRY-701-00812	9
4.6520 - 4.6929	118.16 - 119.20	RDKS-200-11816	RDKS-100-11816	RDCS-011-00298	RDTS-093-00001	RDRY-701-00812	9
4.6831 - 4.7240	118.95 - 119.99	RDKS-200-11895	RDKS-100-11895	RDCS-011-00300	RDTS-094-00001	RDRY-701-00812	9
4.7142 - 4.7551	119.74 - 120.78	RDKS-200-11974	RDKS-100-11974	RDCS-011-00302	RDTS-095-00001	RDRY-701-00812	9
4.7461 - 4.7870	120.55 - 121.59	RDKS-200-12055	RDKS-100-12055	RDCS-011-00304	RDTS-096-00001	RDRY-701-00812	9
4.7772 - 4.8181	121.34 - 122.38	RDKS-200-12134	RDKS-100-12134	RDCS-011-00306	RDTS-097-00001	RDRY-701-00812	9
4.8079 - 4.8492	122.12 - 123.17	RDKS-200-12212	RDKS-100-12212	RDCS-011-00308	RDTS-098-00001	RDRY-701-00812	9
4.8390 - 4.8799	122.91 - 123.95	RDKS-200-12291	RDKS-100-12291	RDCS-011-00310	RDTS-099-00001	RDRY-701-00812	9
4.8709 - 4.9122	123.72 - 124.77	RDKS-200-12372	RDKS-100-12372	RDCS-011-00312	RDTS-100-00001	RDRY-701-00812	9
4.9020 - 4.9429	124.51 - 125.55	RDKS-200-12451	RDKS-100-12451	RDCS-011-01245	RDTS-031-01245	RDRY-701-00812	9
4.9331 - 4.9740	125.30 - 126.34	RDKS-200-12530	RDKS-100-12530	RDCS-011-01255	RDTS-031-01255	RDRY-701-00812	9
4.9642 - 5.0051	126.09 - 127.13	RDKS-200-12609	RDKS-100-12609	RDCS-011-01265	RDTS-031-01265	RDRY-701-00812	9
4.9961 - 5.0370	126.90 - 127.94	RDKS-200-12690	RDKS-100-12690	RDCS-011-01275	RDTS-031-01275	RDRY-701-00812	9

注释：每种滚筒抛光工具都装配有锁紧器、锥体和辊。

D : 42 - 45      D : 40 - 41      D : 38

说明请参见 1 : 1

钻削

B

镗孔

C

铰孔

D

抛光

E

螺纹加工

X

特殊应用



滚筒抛光工具 | 盲孔

s系列 | 直径范围：4.0890" - 5.0370" (103.86 mm - 127.94 mm)

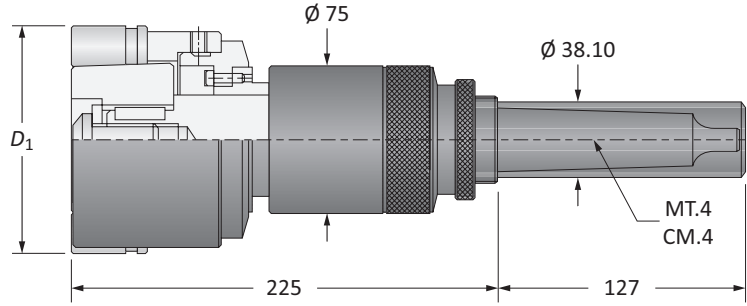

盲孔

D <sub>1</sub>		零件号*		备件			
英制 (in)	公制 (mm)	包含莫氏锥柄的总成	包含直柄的总成	锁紧器	锥体**	辊	辊数量
4.0890 - 4.1299	103.86 - 104.90	RSKS-200-xxxxx	RSKS-100-xxxxx	RSCS-015-00262	RSTS-083-0000x	RSRY-708-00687	9
4.1209 - 4.1634	104.67 - 105.75	RSKS-200-xxxxx	RSKS-100-xxxxx	RSCS-015-00264	RSTS-084-0000x	RSRY-708-00687	9
4.1520 - 4.1929	105.46 - 106.50	RSKS-200-xxxxx	RSKS-100-xxxxx	RSCS-015-00266	RSTS-085-0000x	RSRY-708-00687	9
4.1831 - 4.2240	106.25 - 107.29	RSKS-200-xxxxx	RSKS-100-xxxxx	RSCS-015-00268	RSTS-086-0000x	RSRY-708-00687	9
4.2142 - 4.2551	107.04 - 108.08	RSKS-200-xxxxx	RSKS-100-xxxxx	RSCS-015-00270	RSTS-087-0000x	RSRY-708-00687	9
4.2461 - 4.2870	107.85 - 108.89	RSKS-200-xxxxx	RSKS-100-xxxxx	RSCS-015-00272	RSTS-088-0000x	RSRY-708-00687	9
4.2772 - 4.3181	108.64 - 109.68	RSKS-200-xxxxx	RSKS-100-xxxxx	RSCS-015-00274	RSTS-089-0000x	RSRY-708-00687	9
4.3079 - 4.3492	109.42 - 110.47	RSKS-200-xxxxx	RSKS-100-xxxxx	RSCS-015-00276	RSTS-090-0000x	RSRY-708-00687	9
4.3390 - 4.3799	110.21 - 111.25	RSKS-200-xxxxx	RSKS-100-xxxxx	RSCS-015-00278	RSTS-083-0000x	RSRY-708-00812	9
4.3709 - 4.4122	111.02 - 112.07	RSKS-200-xxxxx	RSKS-100-xxxxx	RSCS-015-00280	RSTS-084-0000x	RSRY-708-00812	9
4.4020 - 4.4429	111.81 - 112.85	RSKS-200-xxxxx	RSKS-100-xxxxx	RSCS-015-00282	RSTS-085-0000x	RSRY-708-00812	9
4.4331 - 4.4740	112.60 - 113.64	RSKS-200-xxxxx	RSKS-100-xxxxx	RSCS-015-00284	RSTS-086-0000x	RSRY-708-00812	9
4.4622 - 4.5051	113.34 - 114.43	RSKS-200-xxxxx	RSKS-100-xxxxx	RSCS-015-00286	RSTS-087-0000x	RSRY-708-00812	9
4.4961 - 4.5370	114.20 - 115.24	RSKS-200-xxxxx	RSKS-100-xxxxx	RSCS-015-00288	RSTS-088-0000x	RSRY-708-00812	9
4.5272 - 4.5681	114.99 - 116.03	RSKS-200-xxxxx	RSKS-100-xxxxx	RSCS-015-00290	RSTS-089-0000x	RSRY-708-00812	9
4.5579 - 4.5992	115.77 - 116.82	RSKS-200-xxxxx	RSKS-100-xxxxx	RSCS-015-00292	RSTS-090-0000x	RSRY-708-00812	9
4.5890 - 4.6299	116.56 - 117.60	RSKS-200-xxxxx	RSKS-100-xxxxx	RSCS-015-00294	RSTS-091-0000x	RSRY-708-00812	9
4.6209 - 4.6622	117.37 - 118.42	RSKS-200-xxxxx	RSKS-100-xxxxx	RSCS-015-00296	RSTS-092-0000x	RSRY-708-00812	9
4.6520 - 4.6929	118.16 - 119.20	RSKS-200-xxxxx	RSKS-100-xxxxx	RSCS-015-00298	RSTS-093-0000x	RSRY-708-00812	9
4.6831 - 4.7240	118.95 - 119.99	RSKS-200-xxxxx	RSKS-100-xxxxx	RSCS-015-00300	RSTS-094-0000x	RSRY-708-00812	9
4.7142 - 4.7551	119.74 - 120.78	RSKS-200-xxxxx	RSKS-100-xxxxx	RSCS-015-00302	RSTS-095-0000x	RSRY-708-00812	9
4.7461 - 4.7870	120.55 - 121.59	RSKS-200-xxxxx	RSKS-100-xxxxx	RSCS-015-00304	RSTS-096-0000x	RSRY-708-00812	9
4.7772 - 4.8181	121.34 - 122.38	RSKS-200-xxxxx	RSKS-100-xxxxx	RSCS-015-00306	RSTS-097-0000x	RSRY-708-00812	9
4.8079 - 4.8492	122.12 - 123.17	RSKS-200-xxxxx	RSKS-100-xxxxx	RSCS-015-00308	RSTS-098-0000x	RSRY-708-00812	9
4.8390 - 4.8799	122.91 - 123.95	RSKS-200-xxxxx	RSKS-100-xxxxx	RSCS-015-00310	RSTS-099-0000x	RSRY-708-00812	9
4.8709 - 4.9122	123.72 - 124.77	RSKS-200-xxxxx	RSKS-100-xxxxx	RSCS-015-00312	RSTS-100-0000x	RSRY-708-00812	9
4.9020 - 4.9429	124.51 - 125.55	RSKS-200-xxxxx	RSKS-100-xxxxx	RSCS-015-01245	RSTS-03x-01245	RSRY-708-00812	9
4.9331 - 4.9740	125.30 - 126.34	RSKS-200-xxxxx	RSKS-100-xxxxx	RSCS-015-01255	RSTS-03x-01255	RSRY-708-00812	9
4.9642 - 5.0051	126.09 - 127.13	RSKS-200-xxxxx	RSKS-100-xxxxx	RSCS-015-01265	RSTS-03x-01265	RSRY-708-00812	9
4.9961 - 5.0370	126.90 - 127.94	RSKS-200-xxxxx	RSKS-100-xxxxx	RSCS-015-01275	RSTS-03x-01275	RSRY-708-00812	9

\*xxxxx = 指示包含2位小数的公制待抛光尺寸 (例如直径为120.05 mm, 带MT.4柄的滚筒抛光工具: RSKS-200-12005)。  
 \*\*x = 一个在2 - 8的范围内变化的数字, 具体取决于精确的待抛光直径。有关 "x" 值的正确识别, 请参见第D : 6页。  
 注释: 每种滚筒抛光工具都装配有锁紧器、锥体和辊。

D : 42 - 45      D : 40 - 41      D : 39

说明请参见D : 1

## 滚筒抛光工具 | 通孔

T系列 | 直径范围：5.0354" - 5.9016" (127.90 mm - 149.90 mm)

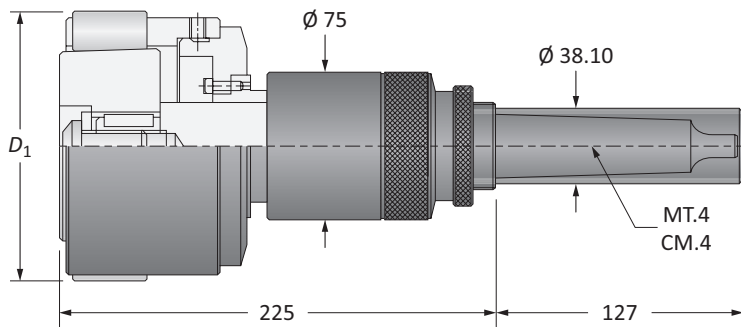

### 通孔

D <sub>1</sub>		零件号		备件			
英制 (in)	公制 (mm)	包含莫氏锥柄的总成	包含直柄的总成	锁紧器	锥体	辊	辊数量
5.0354 - 5.0748	127.90 - 128.90	RDKT-200-12790	RDKT-100-12790	RDCT-011-01280	RDTT-031-01280	RDRY-701-00812	11
5.0748 - 5.1142	128.90 - 129.90	RDKT-200-12890	RDKT-100-12890	RDCT-011-01290	RDTT-031-01290	RDRY-701-00812	11
5.1142 - 5.1535	129.90 - 130.90	RDKT-200-12990	RDKT-100-12990	RDCT-011-01300	RDTT-031-01300	RDRY-701-00812	11
5.1535 - 5.1929	130.90 - 131.90	RDKT-200-13090	RDKT-100-13090	RDCT-011-01310	RDTT-031-01310	RDRY-701-00812	11
5.1929 - 5.2323	131.90 - 132.90	RDKT-200-13190	RDKT-100-13190	RDCT-011-01320	RDTT-031-01320	RDRY-701-00812	11
5.2323 - 5.2717	132.90 - 133.90	RDKT-200-13290	RDKT-100-13290	RDCT-011-01330	RDTT-031-01330	RDRY-701-00812	11
5.2717 - 5.3110	133.90 - 134.90	RDKT-200-13390	RDKT-100-13390	RDCT-011-01340	RDTT-031-01340	RDRY-701-00812	11
5.3110 - 5.3504	134.90 - 135.90	RDKT-200-13490	RDKT-100-13490	RDCT-011-01350	RDTT-031-01350	RDRY-701-00812	11
5.3504 - 5.3898	135.90 - 136.90	RDKT-200-13590	RDKT-100-13590	RDCT-011-01360	RDTT-031-01360	RDRY-701-00812	11
5.3898 - 5.4291	136.90 - 137.90	RDKT-200-13690	RDKT-100-13690	RDCT-011-01370	RDTT-031-01370	RDRY-701-00812	11
5.4291 - 5.4685	137.90 - 138.90	RDKT-200-13790	RDKT-100-13790	RDCT-011-01380	RDTT-031-01380	RDRY-701-00812	11
5.4685 - 5.5079	138.90 - 139.90	RDKT-200-13890	RDKT-100-13890	RDCT-011-01390	RDTT-031-01390	RDRY-701-00812	11
5.5079 - 5.5472	139.90 - 140.90	RDKT-200-13990	RDKT-100-13990	RDCT-011-01400	RDTT-031-01400	RDRY-701-00812	11
5.5472 - 5.5866	140.90 - 141.90	RDKT-200-14090	RDKT-100-14090	RDCT-011-01410	RDTT-031-01410	RDRY-701-00812	11
5.5866 - 5.6260	141.60 - 142.90	RDKT-200-14190	RDKT-100-14190	RDCT-011-01420	RDTT-031-01420	RDRY-701-00812	11
5.6260 - 5.6654	142.90 - 143.90	RDKT-200-14290	RDKT-100-14290	RDCT-011-01430	RDTT-031-01430	RDRY-701-00812	11
5.6654 - 5.7047	143.90 - 144.90	RDKT-200-14390	RDKT-100-14390	RDCT-011-01440	RDTT-031-01440	RDRY-701-00812	11
5.7047 - 5.7441	144.90 - 145.90	RDKT-200-14490	RDKT-100-14490	RDCT-011-01450	RDTT-031-01450	RDRY-701-00812	11
5.7441 - 5.7835	145.90 - 146.90	RDKT-200-14590	RDKT-100-14590	RDCT-011-01460	RDTT-031-01460	RDRY-701-00812	11
5.7835 - 5.8228	146.90 - 147.90	RDKT-200-14690	RDKT-100-14690	RDCT-011-01470	RDTT-031-01470	RDRY-701-00812	11
5.8228 - 5.8622	147.90 - 148.90	RDKT-200-14790	RDKT-100-14790	RDCT-011-01480	RDTT-031-01480	RDRY-701-00812	11
5.8622 - 5.9016	148.90 - 149.90	RDKT-200-14890	RDKT-100-14890	RDCT-011-01490	RDTT-031-01490	RDRY-701-00812	11

注释：每种滚筒抛光工具都装配有锁紧器、锥体和辊。

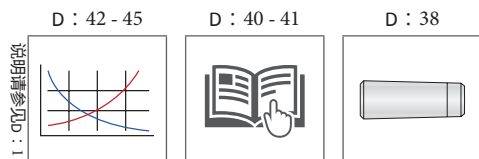



## 滚筒抛光工具 | 盲孔

T系列 | 直径范围：5.0354" - 5.9016" (127.90 mm - 149.90 mm)

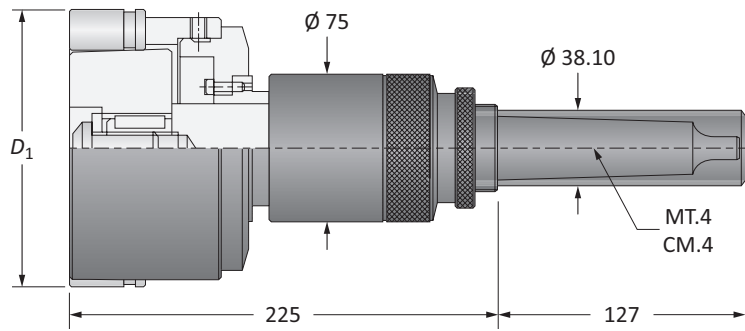

盲孔

D <sub>1</sub>		零件号*		备件			
英制 (in)	公制 (mm)	包含莫氏锥柄的总成	包含直柄的总成	锁紧器	锥体**	辊	辊数量
5.0354 - 5.0748	127.90 - 128.90	RSKT-200-xxxxx	RSKT-100-xxxxx	RSCT-015-01280	RSTT-0xx-01280	RSRY-708-00812	11
5.0748 - 5.1142	128.90 - 129.90	RSKT-200-xxxxx	RSKT-100-xxxxx	RSCT-015-01290	RSTT-0xx-01290	RSRY-708-00812	11
5.1142 - 5.1535	129.90 - 130.90	RSKT-200-xxxxx	RSKT-100-xxxxx	RSCT-015-01300	RSTT-0xx-01300	RSRY-708-00812	11
5.1535 - 5.1929	130.90 - 131.90	RSKT-200-xxxxx	RSKT-100-xxxxx	RSCT-015-01310	RSTT-0xx-01310	RSRY-708-00812	11
5.1929 - 5.2323	131.90 - 132.90	RSKT-200-xxxxx	RSKT-100-xxxxx	RSCT-015-01320	RSTT-0xx-01320	RSRY-708-00812	11
5.2323 - 5.2717	132.90 - 133.90	RSKT-200-xxxxx	RSKT-100-xxxxx	RSCT-015-01330	RSTT-0xx-01330	RSRY-708-00812	11
5.2717 - 5.3110	133.90 - 134.90	RSKT-200-xxxxx	RSKT-100-xxxxx	RSCT-015-01340	RSTT-0xx-01340	RSRY-708-00812	11
5.3110 - 5.3504	134.90 - 135.90	RSKT-200-xxxxx	RSKT-100-xxxxx	RSCT-015-01350	RSTT-0xx-01350	RSRY-708-00812	11
5.3504 - 5.3898	135.90 - 136.90	RSKT-200-xxxxx	RSKT-100-xxxxx	RSCT-015-01360	RSTT-0xx-01360	RSRY-708-00812	11
5.3898 - 5.4291	136.90 - 137.90	RSKT-200-xxxxx	RSKT-100-xxxxx	RSCT-015-01370	RSTT-0xx-01370	RSRY-708-00812	11
5.4291 - 5.4685	137.90 - 138.90	RSKT-200-xxxxx	RSKT-100-xxxxx	RSCT-015-01380	RSTT-0xx-01380	RSRY-708-00812	11
5.4685 - 5.5079	138.90 - 139.90	RSKT-200-xxxxx	RSKT-100-xxxxx	RSCT-015-01390	RSTT-0xx-01390	RSRY-708-00812	11
5.5079 - 5.5472	139.90 - 140.90	RSKT-200-xxxxx	RSKT-100-xxxxx	RSCT-015-01400	RSTT-0xx-01400	RSRY-708-00812	11
5.5472 - 5.5866	140.90 - 141.90	RSKT-200-xxxxx	RSKT-100-xxxxx	RSCT-015-01410	RSTT-0xx-01410	RSRY-708-00812	11
5.5866 - 5.6260	141.60 - 142.90	RSKT-200-xxxxx	RSKT-100-xxxxx	RSCT-015-01420	RSTT-0xx-01420	RSRY-708-00812	11
5.6260 - 5.6654	142.90 - 143.90	RSKT-200-xxxxx	RSKT-100-xxxxx	RSCT-015-01430	RSTT-0xx-01430	RSRY-708-00812	11
5.6654 - 5.7047	143.90 - 144.90	RSKT-200-xxxxx	RSKT-100-xxxxx	RSCT-015-01440	RSTT-0xx-01440	RSRY-708-00812	11
5.7047 - 5.7441	144.90 - 145.90	RSKT-200-xxxxx	RSKT-100-xxxxx	RSCT-015-01450	RSTT-0xx-01450	RSRY-708-00812	11
5.7441 - 5.7835	145.90 - 146.90	RSKT-200-xxxxx	RSKT-100-xxxxx	RSCT-015-01460	RSTT-0xx-01460	RSRY-708-00812	11
5.7835 - 5.8228	146.90 - 147.90	RSKT-200-xxxxx	RSKT-100-xxxxx	RSCT-015-01470	RSTT-0xx-01470	RSRY-708-00812	11
5.8228 - 5.8622	147.90 - 148.90	RSKT-200-xxxxx	RSKT-100-xxxxx	RSCT-015-01480	RSTT-0xx-01480	RSRY-708-00812	11
5.8622 - 5.9016	148.90 - 149.90	RSKT-200-xxxxx	RSKT-100-xxxxx	RSCT-015-01490	RSTT-0xx-01490	RSRY-708-00812	11

\*xxxxx = 指示包含2位小数的公制待抛光尺寸 (例如直径为140.00 mm, 带直柄的滚筒抛光工具: RSKT-100-14000)。

\*\*x = 一个在2 - 8的范围内变化的数字, 具体取决于精确的待抛光直径。有关 "x" 值的正确识别, 请参见第D: 6页。

注释: 每种滚筒抛光工具都装配有锁紧器、锥体和辊。

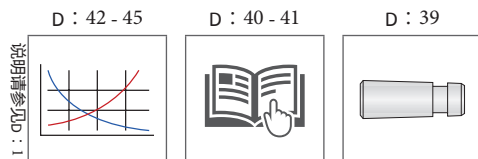

## 滚筒抛光工具 | 通孔

U系列 | 直径范围：5.9016" - 6.5315" (149.90 mm - 165.90 mm)

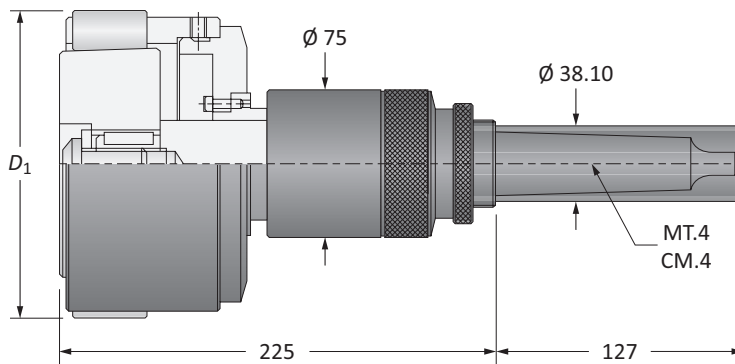

### 通孔

D <sub>1</sub>		零件号		备件			
英制 (in)	公制 (mm)	包含莫氏锥柄的总成	包含直柄的总成	锁紧器	锥体	辊	辊数量
5.9016 - 5.9409	149.90 - 150.90	<b>RDKU-200-14990</b>	<b>RDKU-100-14990</b>	RDCU-011-01500	RDTU-031-01500	RDRY-701-00812	13
5.9409 - 5.9803	150.90 - 151.90	<b>RDKU-200-15090</b>	<b>RDKU-100-15090</b>	RDCU-011-01510	RDTU-031-01510	RDRY-701-00812	13
5.9803 - 6.0197	151.90 - 152.90	<b>RDKU-200-15190</b>	<b>RDKU-100-15190</b>	RDCU-011-01520	RDTU-031-01520	RDRY-701-00812	13
6.0197 - 6.0591	152.90 - 153.90	<b>RDKU-200-15290</b>	<b>RDKU-100-15290</b>	RDCU-011-01530	RDTU-031-01530	RDRY-701-00812	13
6.0591 - 6.0984	153.90 - 154.90	<b>RDKU-200-15390</b>	<b>RDKU-100-15390</b>	RDCU-011-01540	RDTU-031-01540	RDRY-701-00812	13
6.0984 - 6.1378	154.90 - 155.90	<b>RDKU-200-15490</b>	<b>RDKU-100-15490</b>	RDCU-011-01550	RDTU-031-01550	RDRY-701-00812	13
6.1378 - 6.1772	155.90 - 156.90	<b>RDKU-200-15590</b>	<b>RDKU-100-15590</b>	RDCU-011-01560	RDTU-031-01560	RDRY-701-00812	13
6.1772 - 6.2165	156.90 - 157.90	<b>RDKU-200-15690</b>	<b>RDKU-100-15690</b>	RDCU-011-01570	RDTU-031-01570	RDRY-701-00812	13
6.2165 - 6.2559	157.90 - 158.90	<b>RDKU-200-15790</b>	<b>RDKU-100-15790</b>	RDCU-011-01580	RDTU-031-01580	RDRY-701-00812	13
6.2559 - 6.2953	158.90 - 159.90	<b>RDKU-200-15890</b>	<b>RDKU-100-15890</b>	RDCU-011-01590	RDTU-031-01590	RDRY-701-00812	13
6.2953 - 6.3346	159.90 - 160.90	<b>RDKU-200-15990</b>	<b>RDKU-100-15990</b>	RDCU-011-01600	RDTU-031-01600	RDRY-701-00812	13
6.3346 - 6.3740	160.90 - 161.90	<b>RDKU-200-16090</b>	<b>RDKU-100-16090</b>	RDCU-011-01610	RDTU-031-01610	RDRY-701-00812	13
6.3740 - 6.4134	161.90 - 162.90	<b>RDKU-200-16190</b>	<b>RDKU-100-16190</b>	RDCU-011-01620	RDTU-031-01620	RDRY-701-00812	13
6.4134 - 6.4528	162.90 - 163.90	<b>RDKU-200-16290</b>	<b>RDKU-100-16290</b>	RDCU-011-01630	RDTU-031-01630	RDRY-701-00812	13
6.4528 - 6.4921	163.90 - 164.90	<b>RDKU-200-16390</b>	<b>RDKU-100-16390</b>	RDCU-011-01640	RDTU-031-01640	RDRY-701-00812	13
6.4921 - 6.5315	164.90 - 165.90	<b>RDKU-200-16490</b>	<b>RDKU-100-16490</b>	RDCU-011-01650	RDTU-031-01650	RDRY-701-00812	13

注释：每种滚筒抛光工具都装配有锁紧器、锥体和辊。

D : 42 - 45

D : 40 - 41

D : 38

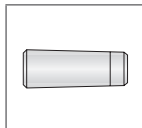
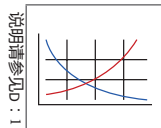

说明请参见 1 :



## 滚筒抛光工具 | 盲孔

U系列 | 直径范围：5.9016" - 6.5315" (149.90 mm - 165.90 mm)

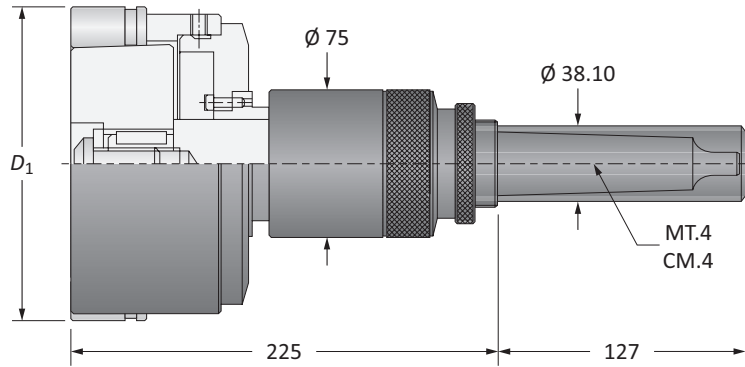

盲孔

D <sub>1</sub>		零件号*		备件			
英制 (in)	公制 (mm)	包含莫氏锥柄的总成	包含直柄的总成	锁紧器	锥体**	辊	辊数量
5.9016 - 5.9409	149.90 - 150.90	RSKU-200-xxxxx	RSKU-100-xxxxx	RSCU-015-01500	RSTU-0xx-01500	RSRY-708-00812	13
5.9409 - 5.9803	150.90 - 151.90	RSKU-200-xxxxx	RSKU-100-xxxxx	RSCU-015-01510	RSTU-0xx-01510	RSRY-708-00812	13
5.9803 - 6.0197	151.90 - 152.90	RSKU-200-xxxxx	RSKU-100-xxxxx	RSCU-015-01520	RSTU-0xx-01520	RSRY-708-00812	13
6.0197 - 6.0591	152.90 - 153.90	RSKU-200-xxxxx	RSKU-100-xxxxx	RSCU-015-01530	RSTU-0xx-01530	RSRY-708-00812	13
6.0591 - 6.0984	153.90 - 154.90	RSKU-200-xxxxx	RSKU-100-xxxxx	RSCU-015-01540	RSTU-0xx-01540	RSRY-708-00812	13
6.0984 - 6.1378	154.90 - 155.90	RSKU-200-xxxxx	RSKU-100-xxxxx	RSCU-015-01550	RSTU-0xx-01550	RSRY-708-00812	13
6.1378 - 6.1772	155.90 - 156.90	RSKU-200-xxxxx	RSKU-100-xxxxx	RSCU-015-01560	RSTU-0xx-01560	RSRY-708-00812	13
6.1772 - 6.2165	156.90 - 157.90	RSKU-200-xxxxx	RSKU-100-xxxxx	RSCU-015-01570	RSTU-0xx-01570	RSRY-708-00812	13
6.2165 - 6.2559	157.90 - 158.90	RSKU-200-xxxxx	RSKU-100-xxxxx	RSCU-015-01580	RSTU-0xx-01580	RSRY-708-00812	13
6.2559 - 6.2953	158.90 - 159.90	RSKU-200-xxxxx	RSKU-100-xxxxx	RSCU-015-01590	RSTU-0xx-01590	RSRY-708-00812	13
6.2953 - 6.3346	159.90 - 160.90	RSKU-200-xxxxx	RSKU-100-xxxxx	RSCU-015-01600	RSTU-0xx-01600	RSRY-708-00812	13
6.3346 - 6.3740	160.90 - 161.90	RSKU-200-xxxxx	RSKU-100-xxxxx	RSCU-015-01610	RSTU-0xx-01610	RSRY-708-00812	13
6.3740 - 6.4134	161.90 - 162.90	RSKU-200-xxxxx	RSKU-100-xxxxx	RSCU-015-01620	RSTU-0xx-01620	RSRY-708-00812	13
6.4134 - 6.4528	162.90 - 163.90	RSKU-200-xxxxx	RSKU-100-xxxxx	RSCU-015-01630	RSTU-0xx-01630	RSRY-708-00812	13
6.4528 - 6.4921	163.90 - 164.90	RSKU-200-xxxxx	RSKU-100-xxxxx	RSCU-015-01640	RSTU-0xx-01640	RSRY-708-00812	13
6.4921 - 6.5315	164.90 - 165.90	RSKU-200-xxxxx	RSKU-100-xxxxx	RSCU-015-01650	RSTU-0xx-01650	RSRY-708-00812	13

\*xxxxx = 指示包含2位小数的公制待抛光尺寸 (例如直径为160.00 mm, 带MT.4柄的滚筒抛光工具: RSKU-200-16000)。  
 \*\*x = 一个在2-8的范围内变化的数字, 具体取决于精确的待抛光直径。有关“x”值的正确识别, 请参见第D: 6页。  
 注释: 每种滚筒抛光工具都装配有锁紧器、锥体和辊。

D : 42 - 45      D : 40 - 41      D : 39

说明请参见D : 1

U  
A  
B  
C  
D  
E  
X

钻削  
镗孔  
铰孔  
抛光  
螺纹加工  
特殊应用

辊  
通孔

辊704和707

零件号	英制 (in)		公制 (mm)	
	D	L	D	L
RDRY-704-00047	0.0465	0.2500	1.18	6.35
RDRY-704-00062	0.0618	0.2500	1.57	6.35
RDRY-704-00070	0.0697	0.3126	1.77	7.94
RDRY-704-00078	0.0776	0.3752	1.97	9.53
RDRY-704-00086	0.0854	0.3752	2.17	9.53
RDRY-704-00093	0.0929	0.3752	2.36	9.53
RDRY-704-00109	0.1083	0.5000	2.75	12.70
RDRY-704-00125	0.1244	0.5000	3.16	12.70
RDRY-704-00148	0.1472	0.5000	3.74	12.70
RDRY-704-00156	0.1555	0.5000	3.95	12.70
RDRY-704-00172	0.1709	0.6252	4.34	15.88
RDRY-704-00187	0.1858	0.8772	4.72	22.28
RDRY-707-00187	0.1870	0.5000	4.75	12.70
RDRY-704-00218	0.2173	0.5000	5.52	12.70
RDRY-707-00218	0.2173	1.0000	5.52	25.40
RDRY-704-00265	0.2638	1.1252	6.70	28.58
RDRY-704-00312	0.3110	1.5000	7.90	38.10
RDRY-707-00312	0.3118	1.1252	7.92	28.58
RDRY-704-00406	0.4047	1.5000	10.28	38.10
RDRY-704-00468	0.4669	1.5000	11.86	38.10
RDRY-704-00531	0.5299	1.5000	13.46	38.10
RDRY-704-00625	0.6240	1.5000	15.85	38.10
RDRY-704-00687	0.6858	1.5000	17.42	38.10
RDRY-704-00812	0.8110	1.5000	20.60	38.10

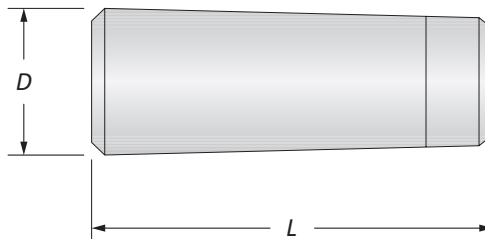

辊701

零件号	英制 (in)		公制 (mm)	
	D	L	D	L
RDRY-701-00187	0.1831	0.8772	4.65	22.28
RDRY-701-00218	0.2138	1.0000	5.43	25.40
RDRY-701-00265	0.2610	1.1252	6.63	28.58
RDRY-701-00312	0.3039	1.5000	7.72	38.10
RDRY-701-00406	0.3980	1.5000	10.11	38.10
RDRY-701-00468	0.4598	1.5000	11.68	38.10
RDRY-701-00531	0.5228	1.5000	13.28	38.10
RDRY-701-00625	0.6169	1.5000	15.67	38.10
RDRY-701-00687	0.6799	1.5000	17.27	38.10
RDRY-701-00812	0.8039	1.5000	20.42	38.10

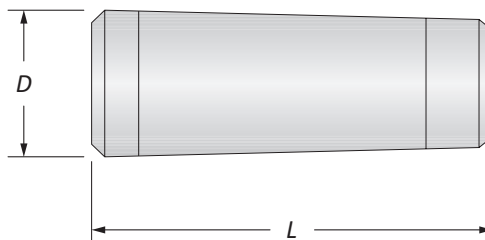

A 钻削  
B 镗孔  
C 绞孔  
D 抛光  
E 螺纹加工  
X 特殊应用



辊  
盲孔

辊708

零件号	英制 (in)		公制 (mm)	
	<i>D</i>	<i>L</i>	<i>D</i>	<i>L</i>
RSRY-708-00086	0.0854	0.3752	2.17	9.53
RSRY-708-00125	0.1244	0.5000	3.16	12.70
RSRY-708-00156	0.1555	0.5000	3.95	12.70
RSRY-708-00172	0.1709	0.6252	4.35	15.88
RSRY-708-00187	0.1858	0.8772	4.72	22.28
RSRY-708-00218	0.2173	0.5000	5.52	25.40
RSRY-708-00265	0.2638	1.1252	6.70	28.58
RSRY-708-00312	0.3110	1.5000	7.90	38.10
RSRY-708-00406	0.4047	1.5000	10.29	38.10
RSRY-708-00468	0.4669	1.5000	11.86	38.10
RSRY-708-00531	0.5299	1.5000	13.46	38.10
RSRY-708-00625	0.6240	1.5000	15.85	38.10
RSRY-708-00687	0.6858	1.5000	17.42	38.10
RSRY-708-00812	0.8110	1.5000	20.60	38.10

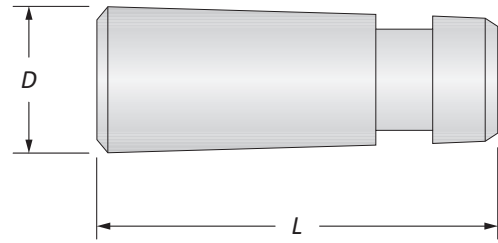

A

钻削

B

镗孔

C

铰孔

D

抛光

E

螺纹加工

X

特殊应用

## 直径调节

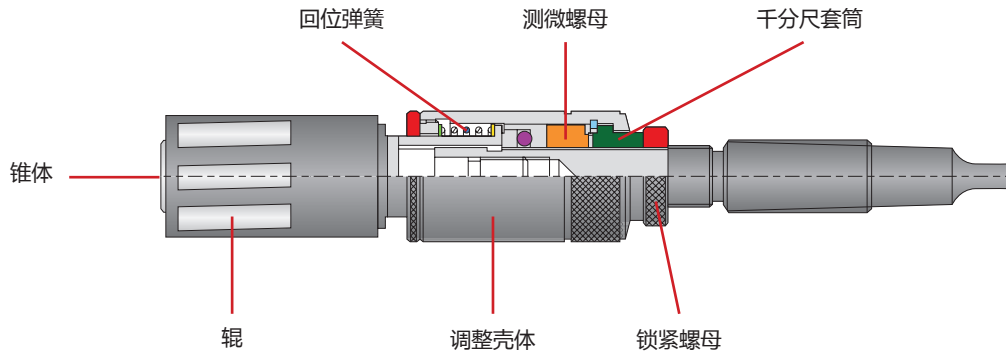

### 调整

滚筒抛光工具包括手柄、刀体以及由固定笼均匀隔开的圆锥滚子行星系统。

1. 拧开锁定螺母。
2. 将外壳拉向锁定螺母并旋转，以增大或减小直径。
3. 拧紧锁定螺母。

重要说明：随着直径的增大，锥体向前移动，将辊推出。因此，锥体将从固定笼端伸出，这样会减小盲孔公差 (参见图1和2)。

关于公差值，请参见下表。

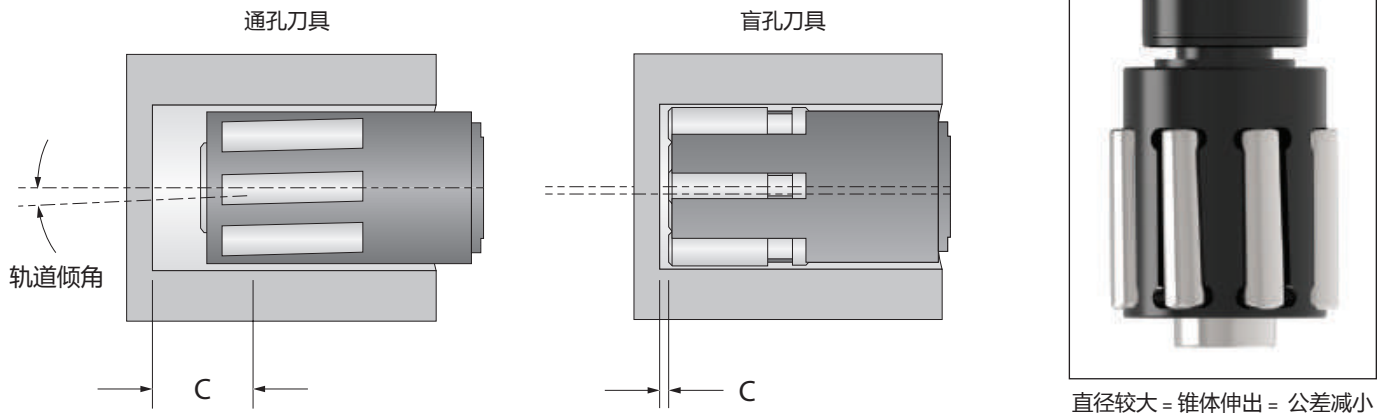

调整范围		公差 (C)		
		通孔		盲孔
英制 (in)	公制 (mm)	辊701	辊704 / 707	辊708
0.1850 - 0.2315	4.70 - 5.88	-	2.40	-
0.2319 - 0.3728	5.89 - 9.47	-	2.40	0.60
0.3732 - 0.6236	9.48 - 15.84	-	2.40	0.60
0.6240 - 1.1236	15.85 - 28.54	5.40	3.20	1.00
1.1240 - 1.8385	28.55 - 46.70	9.50	3.20	1.00
1.8390 - 3.3386	46.71 - 84.80	9.50	4.00	1.00
3.3390 - 6.5315	84.81 - 165.90	10.30	4.70	1.00

## 工作原理

### 滚筒抛光工具

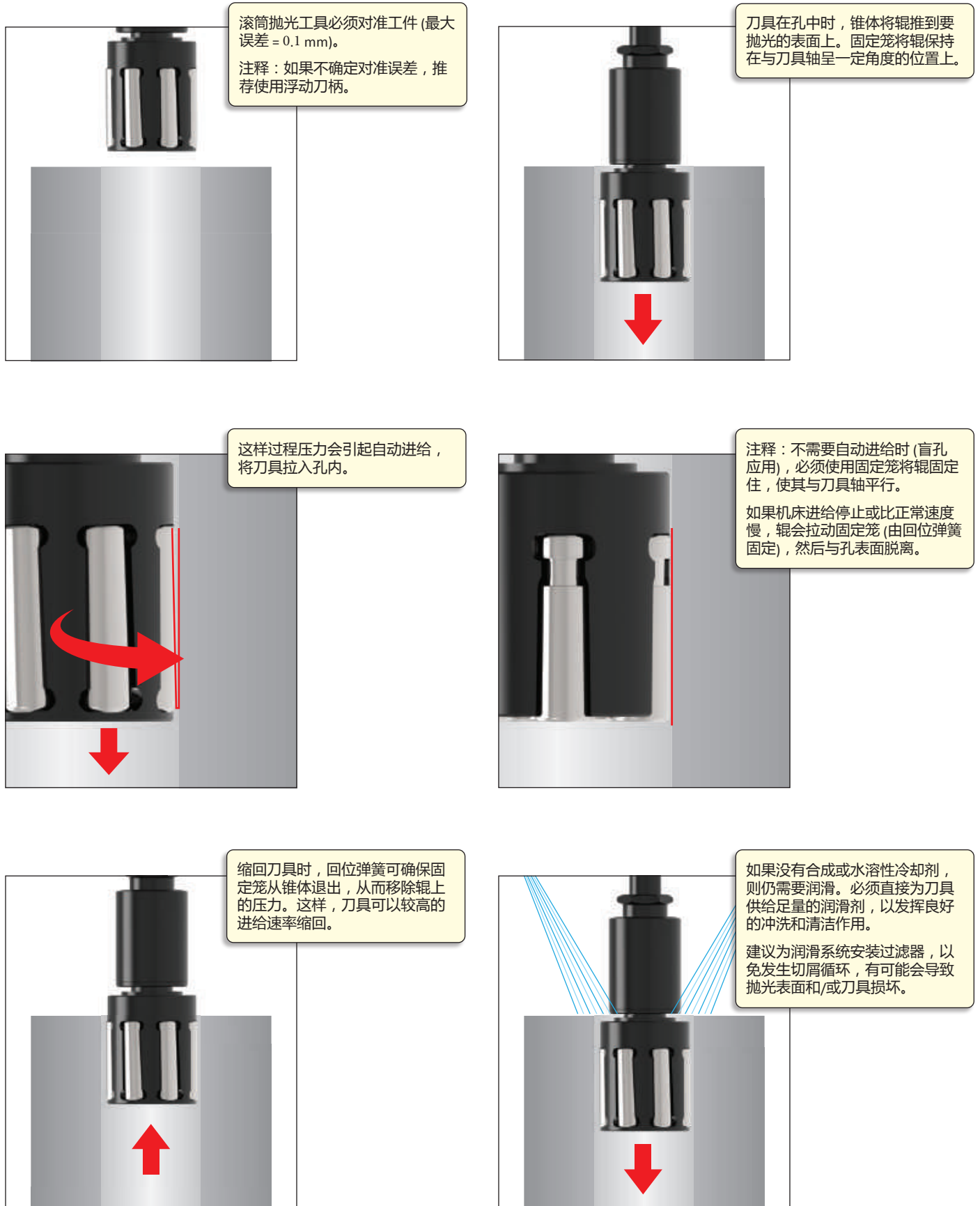

A

钻削

B

镗孔

C

铰孔

D

抛光

E

螺纹加工

X

特殊应用

## 推荐的切削参数 | 英制 (英寸)

### 滚筒抛光

ISO 材料	硬度 (BHN)	速度 (SFM)	推荐进给 (IPR) (按抛光工具直径)			
			0.1850 - 0.4724	0.4725 - 0.9843	0.9844 - 1.9685	1.9686 - 6.5315
P 易加工钢 1118、1215、12L14等 低碳钢 1010、1020、1025、1522、1144等 中碳钢 1030、1040、1050、1527、1140、1151等 合金钢 4140、5140、8640等 高强度合金 4340、4330V、300M等 结构钢 A36、A285、A516等 工具钢 H-13、H-21、A-4、O-2、S-3等	100 - 180	75 - 300	0.005 - 0.020	0.014 - 0.037	0.032 - 0.086	0.070 - 0.121
	180 - 250	75 - 300	0.005 - 0.020	0.014 - 0.037	0.032 - 0.086	0.070 - 0.121
	85 - 180	75 - 300	0.005 - 0.020	0.014 - 0.037	0.032 - 0.086	0.070 - 0.121
	180 - 275	75 - 300	0.005 - 0.020	0.014 - 0.037	0.032 - 0.086	0.070 - 0.121
	125 - 180	75 - 300	0.005 - 0.020	0.014 - 0.037	0.032 - 0.086	0.070 - 0.121
	180 - 325	75 - 300	0.005 - 0.020	0.014 - 0.037	0.032 - 0.086	0.070 - 0.121
	125 - 180	75 - 300	0.005 - 0.020	0.014 - 0.037	0.032 - 0.086	0.070 - 0.121
	180 - 375	75 - 300	0.005 - 0.020	0.014 - 0.037	0.032 - 0.086	0.070 - 0.121
	240 - 450	75 - 300	0.005 - 0.020	0.014 - 0.037	0.032 - 0.086	0.070 - 0.121
	125 - 180	75 - 300	0.005 - 0.020	0.014 - 0.037	0.032 - 0.086	0.070 - 0.121
	180 - 350	75 - 300	0.005 - 0.020	0.014 - 0.037	0.032 - 0.086	0.070 - 0.121
	150 - 200	75 - 300	0.005 - 0.020	0.014 - 0.037	0.032 - 0.086	0.070 - 0.121
200 - 250	75 - 300	0.005 - 0.020	0.014 - 0.037	0.032 - 0.086	0.070 - 0.121	
S 高温合金 Hastelloy B、Inconel 600等 钛合金	140 - 310	50 - 150	0.005 - 0.020	0.014 - 0.037	0.032 - 0.086	0.070 - 0.121
	140 - 310	50 - 150	0.005 - 0.020	0.014 - 0.037	0.032 - 0.086	0.070 - 0.121
M 400系列不锈钢 416、420等 300系列不锈钢 304、316、17-4PH等	135 - 350	75 - 200	0.005 - 0.020	0.014 - 0.037	0.032 - 0.086	0.070 - 0.121
	135 - 275	75 - 200	0.005 - 0.020	0.014 - 0.037	0.032 - 0.086	0.070 - 0.121
K 灰口铸铁、球墨铸铁、 球墨铸铁 (珠光体) 球墨铸铁 (铁素体)	< 200	75 - 300	0.005 - 0.020	0.014 - 0.037	0.032 - 0.086	0.070 - 0.121
	> 200	75 - 300	0.005 - 0.020	0.014 - 0.037	0.032 - 0.086	0.070 - 0.121
	260 - 320	75 - 300	0.005 - 0.020	0.014 - 0.037	0.032 - 0.086	0.070 - 0.121
N 铜和合金 黄铜 青铜 青铜磷 铝和合金	< 500	150 - 350	0.005 - 0.020	0.014 - 0.037	0.032 - 0.086	0.070 - 0.121
	< 180	150 - 350	0.005 - 0.020	0.014 - 0.037	0.032 - 0.086	0.070 - 0.121
	< 150	150 - 350	0.005 - 0.020	0.014 - 0.037	0.032 - 0.086	0.070 - 0.121
	< 150	150 - 350	0.005 - 0.020	0.014 - 0.037	0.032 - 0.086	0.070 - 0.121

### 最高转速

系列	最高转速
H	2000
I	1500
K	1200
L	1000
F	1000
M	900
N	900
O	700
P	600
Q	500
R	300
S	300
T	250
U	200

重要说明：这些页所列的速度和进给是所有应用的通用起始值。我们的应用工程部门可为您提供工厂技术援助。

机械加工余量 | 英制 (in)

滚筒抛光

ISO 材料	硬度 (BHN)	推荐余量 (in) (按抛光工具直径)*			
		0.1850 - 0.4724	0.4725 - 0.9843	0.9844 - 1.9685	1.9686 - 6.5315
P 易加工钢 1118、1215、12L14等 低碳钢 1010、1020、1025、1522、1144等 中碳钢 1030、1040、1050、1527、1140、1151等 合金钢 4140、5140、8640等 高强度合金 4340、4330V、300M等 结构钢 A36、A285、A516等 工具钢 H-13、H-21、A-4、0-2、S-3等	100 - 180	0.0004 - 0.0007	0.0007 - 0.0016	0.0010 - 0.0018	0.0012 - 0.0020
	180 - 250	0.0004 - 0.0007	0.0007 - 0.0016	0.0010 - 0.0018	0.0012 - 0.0020
	85 - 180	0.0004 - 0.0007	0.0007 - 0.0016	0.0010 - 0.0018	0.0012 - 0.0020
	180 - 275	0.0004 - 0.0007	0.0007 - 0.0016	0.0010 - 0.0018	0.0012 - 0.0020
	125 - 180	0.0004 - 0.0007	0.0007 - 0.0016	0.0010 - 0.0018	0.0012 - 0.0020
	180 - 325	0.0004 - 0.0007	0.0005 - 0.0007	0.0005 - 0.0010	0.0008 - 0.0014
	125 - 180	0.0004 - 0.0007	0.0007 - 0.0016	0.0010 - 0.0018	0.0012 - 0.0020
	180 - 375	0.0004 - 0.0007	0.0005 - 0.0007	0.0005 - 0.0010	0.0008 - 0.0014
	240 - 450	0.0004 - 0.0007	0.0005 - 0.0007	0.0005 - 0.0010	0.0008 - 0.0014
	125 - 180	0.0004 - 0.0007	0.0007 - 0.0016	0.0010 - 0.0018	0.0012 - 0.0020
180 - 350	0.0004 - 0.0007	0.0005 - 0.0007	0.0005 - 0.0010	0.0008 - 0.0014	
150 - 200	0.0004 - 0.0007	0.0007 - 0.0016	0.0010 - 0.0018	0.0012 - 0.0020	
200 - 250	0.0004 - 0.0007	0.0005 - 0.0007	0.0005 - 0.0010	0.0008 - 0.0014	
S 高温合金 Hastelloy B、Inconel 600等 钛合金	140 - 310	0.0004 - 0.0007	0.0005 - 0.0007	0.0005 - 0.0010	0.0008 - 0.0014
	140 - 310	0.0004 - 0.0007	0.0005 - 0.0007	0.0005 - 0.0010	0.0008 - 0.0014
M 400系列不锈钢 416、420等 300系列不锈钢 304、316、17-4PH等	135 - 350	0.0004 - 0.0007	0.0007 - 0.0016	0.0010 - 0.0018	0.0012 - 0.0020
	135 - 275	0.0004 - 0.0007	0.0007 - 0.0016	0.0010 - 0.0018	0.0012 - 0.0020
K 灰口铸铁、球墨铸铁、 球墨铸铁 (珠光体) 球墨铸铁 (铁素体)	< 200	0.0004 - 0.0007	0.0005 - 0.0007	0.0005 - 0.0010	0.0008 - 0.0014
	> 200	0.0004 - 0.0007	0.0005 - 0.0007	0.0005 - 0.0010	0.0008 - 0.0014
	260 - 320	0.0004 - 0.0007	0.0005 - 0.0007	0.0005 - 0.0010	0.0008 - 0.0014
N 铜和合金 黄铜 青铜 青铜磷 铝和合金	< 500	0.0004 - 0.0007	0.0007 - 0.0016	0.0010 - 0.0018	0.0012 - 0.0020
	< 180	0.0004 - 0.0007	0.0007 - 0.0016	0.0010 - 0.0018	0.0012 - 0.0020
	< 150	0.0004 - 0.0007	0.0007 - 0.0016	0.0010 - 0.0018	0.0012 - 0.0020
	< 150	0.0004 - 0.0007	0.0007 - 0.0016	0.0010 - 0.0018	0.0012 - 0.0020

\*该余量值为直径余量。

A

钻削

B

镗孔

C

铰孔

D

抛光

E

螺纹加工

X

特殊应用

推荐的切削参数 | 公制 (mm)

滚筒抛光

ISO 材料	硬度 (BHN)	速度 (M/min)	推荐进给 (mm/rev) (按抛光工具直径)			
			4.70 - 12.00	12.01 - 25.00	25.01 - 50.00	50.01 - 165.90
P 易加工钢 1118、1215、12L14等 低碳钢 1010、1020、1025、1522、1144等 中碳钢 1030、1040、1050、1527、1140、1151等 合金钢 4140、5140、8640等 高强度合金 4340、4330V、300M等 结构钢 A36、A285、A516等 工具钢 H-13、H-21、A-4、0-2、S-3等	100 - 180	22 - 90	0.13 - 0.51	0.36 - 0.94	0.81 - 2.18	1.78 - 3.07
	180 - 250	22 - 90	0.13 - 0.51	0.36 - 0.94	0.81 - 2.18	1.78 - 3.07
	85 - 180	22 - 90	0.13 - 0.51	0.36 - 0.94	0.81 - 2.18	1.78 - 3.07
	180 - 275	22 - 90	0.13 - 0.51	0.36 - 0.94	0.81 - 2.18	1.78 - 3.07
	125 - 180	22 - 90	0.13 - 0.51	0.36 - 0.94	0.81 - 2.18	1.78 - 3.07
	180 - 325	22 - 90	0.13 - 0.51	0.36 - 0.94	0.81 - 2.18	1.78 - 3.07
	125 - 180	22 - 90	0.13 - 0.51	0.36 - 0.94	0.81 - 2.18	1.78 - 3.07
	180 - 375	22 - 90	0.13 - 0.51	0.36 - 0.94	0.81 - 2.18	1.78 - 3.07
	240 - 450	22 - 90	0.13 - 0.51	0.36 - 0.94	0.81 - 2.18	1.78 - 3.07
	125 - 180	22 - 90	0.13 - 0.51	0.36 - 0.94	0.81 - 2.18	1.78 - 3.07
	180 - 350	22 - 90	0.13 - 0.51	0.36 - 0.94	0.81 - 2.18	1.78 - 3.07
	150 - 200	22 - 90	0.13 - 0.51	0.36 - 0.94	0.81 - 2.18	1.78 - 3.07
200 - 250	22 - 90	0.13 - 0.51	0.36 - 0.94	0.81 - 2.18	1.78 - 3.07	
S 高温合金 Hastelloy B、Inconel 600等 钛合金	140 - 310	15 - 45	0.13 - 0.51	0.36 - 0.94	0.81 - 2.18	1.78 - 3.07
	140 - 310	15 - 45	0.13 - 0.51	0.36 - 0.94	0.81 - 2.18	1.78 - 3.07
M 400系列不锈钢 416、420等 300系列不锈钢 304、316、17-4PH等	135 - 350	22 - 60	0.13 - 0.51	0.36 - 0.94	0.81 - 2.18	1.78 - 3.07
	135 - 275	22 - 60	0.13 - 0.51	0.36 - 0.94	0.81 - 2.18	1.78 - 3.07
K 灰口铸铁、球墨铸铁、 球墨铸铁 (珠光体) 球墨铸铁 (铁素体)	< 200	22 - 90	0.13 - 0.51	0.36 - 0.94	0.81 - 2.18	1.78 - 3.07
	> 200	22 - 90	0.13 - 0.51	0.36 - 0.94	0.81 - 2.18	1.78 - 3.07
	260 - 320	22 - 90	0.13 - 0.51	0.36 - 0.94	0.81 - 2.18	1.78 - 3.07
N 铜和合金 黄铜 青铜 青铜磷 铝和合金	< 500	45 - 105	0.13 - 0.51	0.36 - 0.94	0.81 - 2.18	1.78 - 3.07
	< 180	45 - 105	0.13 - 0.51	0.36 - 0.94	0.81 - 2.18	1.78 - 3.07
	< 150	45 - 105	0.13 - 0.51	0.36 - 0.94	0.81 - 2.18	1.78 - 3.07
	< 150	45 - 105	0.13 - 0.51	0.36 - 0.94	0.81 - 2.18	1.78 - 3.07

最高转速

系列	最高转速
H	2000
I	1500
K	1200
L	1000
F	1000
M	900
N	900
O	700
P	600
Q	500
R	300
S	300
T	250
U	200

重要说明：这些页所列的速度和进给是所有应用的通用起始值。我们的应用工程部门可为您提供工厂技术援助。

机械加工余量 | 公制 (mm)

滚筒抛光

ISO 材料	硬度 (BHN)	推荐余量 (mm) (按抛光工具直径)*				
		4.70 - 12.00	12.01 - 25.00	25.01 - 50.00	50.01 - 165.90	
P	易加工钢 1118、1215、12L14等	100 - 180	0.010 - 0.018	0.018 - 0.041	0.025 - 0.046	0.030 - 0.051
	低碳钢 1010、1020、1025、1522、1144等	180 - 250	0.010 - 0.018	0.018 - 0.041	0.025 - 0.046	0.030 - 0.051
	中碳钢 1030、1040、1050、1527、1140、1151等	85 - 180	0.010 - 0.018	0.018 - 0.041	0.025 - 0.046	0.030 - 0.051
		180 - 275	0.010 - 0.018	0.018 - 0.041	0.025 - 0.046	0.030 - 0.051
	合金钢 4140、5140、8640等	125 - 180	0.010 - 0.018	0.018 - 0.041	0.025 - 0.046	0.030 - 0.051
		180 - 325	0.010 - 0.018	0.012 - 0.018	0.012 - 0.025	0.020 - 0.036
	高强度合金 4340、4330V、300M等	125 - 180	0.010 - 0.018	0.018 - 0.041	0.025 - 0.046	0.030 - 0.051
		180 - 350	0.010 - 0.018	0.012 - 0.018	0.012 - 0.025	0.020 - 0.036
	工具钢 H-13、H-21、A-4、0-2、S-3等	150 - 200	0.010 - 0.018	0.018 - 0.041	0.025 - 0.046	0.030 - 0.051
		200 - 250	0.010 - 0.018	0.012 - 0.018	0.012 - 0.025	0.020 - 0.036
S	高温合金 Hastelloy B、Inconel 600等	140 - 310	0.010 - 0.018	0.012 - 0.018	0.012 - 0.025	0.020 - 0.036
	钛合金	140 - 310	0.010 - 0.018	0.012 - 0.018	0.012 - 0.025	0.020 - 0.036
M	400系列不锈钢 416、420等	135 - 350	0.010 - 0.018	0.018 - 0.041	0.025 - 0.046	0.030 - 0.051
	300系列不锈钢 304、316、17-4PH等	135 - 275	0.010 - 0.018	0.018 - 0.041	0.025 - 0.046	0.030 - 0.051
K	灰口铸铁、球墨铸铁、 球墨铸铁 (珠光体)	< 200	0.010 - 0.018	0.012 - 0.018	0.012 - 0.025	0.020 - 0.036
		> 200	0.010 - 0.018	0.012 - 0.018	0.012 - 0.025	0.020 - 0.036
	球墨铸铁 (铁素体)	260 - 320	0.010 - 0.018	0.012 - 0.018	0.012 - 0.025	0.020 - 0.036
N	铜和合金 黄铜	< 500	0.010 - 0.018	0.018 - 0.041	0.025 - 0.046	0.030 - 0.051
	青铜 青铜磷	< 180	0.010 - 0.018	0.018 - 0.041	0.025 - 0.046	0.030 - 0.051
	铝和合金	< 150	0.010 - 0.018	0.018 - 0.041	0.025 - 0.046	0.030 - 0.051

\*该余量值为直径余量。

A

钻削

B

镗孔

C

铰孔

D

抛光

E

螺纹加工

X

特殊应用









## 保修信息



美国联合机械工程公司向本公司产品的原始设备制造商、经销商、工业和商业用户保证，本公司制造或提供的每款新产品在材料和工艺方面均无缺陷。

美国联合机械工程公司在本保修项下的义务仅限于：为在自销售日期起1年内以预付运费方式退回至美国联合机械工程公司代表指定的工厂，并且经美国联合机械工程公司检查后确定在材料或工艺方面存在缺陷的任何产品提供免费换货或自行选择维修或退款服务。

退回进行检查的任何产品都应随附提供与运行条件、机床、装夹和切削液应用有关的完整信息。本保修的条款不适用于美国联合机械工程公司的任何以下产品：经历过不当使用、不适当的运行条件、机床装夹或切削液应用，或经历过维修或改装且此类维修或改装经美国联合机械工程公司判断会对产品性能产生不利影响。

本保修取代所有其他明示或默示保证，包括对适销性或特定用途适用性的任何默示保证。对于因制造、销售、交付或使用依此销售的任何产品而产生、关联或造成的任何损失或损害而进行的任何形式的任何索赔（无论以合同、侵权行为还是其他方式），美国联合机械工程公司不承担任何责任或义务。

保留对所有价格、交付条款、设计和材料做出修改的权利，恕不另行通知。



美国联合机械工程公司  
获得ISO 9001  
10001329认证

## United States

### Allied Machine & Engineering

120 Deeds Drive  
Dover OH 44622  
United States

**Phone:**  
+1.330.343.4283

**Fax:**  
+1.330.602.3400

**Toll Free USA and Canada:**  
800.321.5537

**Toll Free USA and Canada:**  
800.223.5140

### Allied Machine & Engineering

485 W Third Street  
Dover OH 44622  
United States

**Phone:**  
+1.330.343.4283

**Fax:**  
+1.330.364.7666  
(Engineering Dept.)

**Toll Free USA and Canada:**  
800.321.5537

## Europe

### Allied Machine & Engineering Co. (Europe) Ltd.

93 Vantage Point  
Pensnett Estate  
Kingswinford  
West Midlands  
DY6 7FR England

**Phone:**  
+44 (0) 1384.400900

### Wohlhaupter GmbH

Maybachstrasse 4  
Postfach 1264  
72636 Frickenhausen  
Germany

**Phone:**  
+49 (0) 7022.408.0

**Fax:**  
+49 (0) 7022.408.212

## Asia

### Wohlhaupter India Pvt. Ltd.

B-23, 2nd Floor  
B Block Community Centre  
Janakpuri, New Delhi - 110058  
India

**Phone:**  
+91 (0) 11.41827044



日易晖 机械

## GOLDEN CARBIDE PRECISION

上海市天钥桥路325号嘉汇国际广场A栋2101-2102室 邮编: 200030

台北市大安区敦化南路二段40号2楼 邮政编码: 106

上海: 86-21-3363-2088

天津: 86-22-5817-3069

成都: 86-28-8526-6681

长春: 86-431-8461-7085

重庆: 86-23-6757-3205

外高桥保税库: 86-21-5868-3075

台北: 886-2-2705-8448

台中: 886-4-2463-8159

Website: [www.goldencarbide.com](http://www.goldencarbide.com)